



Mission Critical Facilities, Data Centers, Technology Spaces and Electronic Equipment

2026 ASHRAE Winter Conference

Las Vegas, NV

Workshops Meeting

Sunday February 1, 2026

Hybrid In-Person / Virtual

Welcome to the...

ASHRAE TC 9.9 Subcommittee

Hybrid In-Person/Virtual Meeting

High Level Agenda

- Welcome
- Workshop Primers
- Workgroup Sessions

Meeting Organizers

Meeting Host: Mark Steinke - *Chair*

- Organize the meeting content
- Introduce topics
- Moderate discussions
- Manage screen-sharing and in-person presentation

Virtual Host: John Gross - *Vice Chair*

- Monitor the chat for questions and comments
- Mute and Unmute Virtual Participants
- Manage discussions and voting

Virtual Co-Host: Chris Campbell - *Secretary*

- Monitor time and keep the meeting on schedule
- Record the event
- Produce meeting minutes
- Respond to audio problems
- Add the attendance link to the chat

TC 9.9 Workshops

(Programs, Research, Handbook, & Encyclopedia)

Time: Sunday - February 1, 2026 4:00 PM – 6:00 PM PST

Location: Caesars Palace, Octavius 10 (PS)

Virtual: <https://www.microsoft.com/microsoft-teams/join-a-meeting>

Meeting ID: 243 563 127 885 0

Passcode: mT2Xr6aY

Section	Topic	Time	Presenter
Welcome	Welcome & Agenda	10	Mark Steinke
Programs Subcommittee	Workshop Primer	5	Eric Yang
Research Subcommittee	Workshop Primer	5	Brad Cochran
Handbook Subcommittee	Workshop Primer	5	Robert McFarlane Jonell Watson
Publications Subcommittee	Workshop Primer	5	Dustin Demetriou
Workgroup Sessions	Track 1: Encyclopedia Track 2: Handbook Track 3: Programs Track 4: Research	90	Dustin Demetriou Jonell Watson Eric Yang Brad Cochran
Total Time:		120	Minutes

Housekeeping & Meeting Etiquette

General Meeting Etiquette

- Individuals should state their name & affiliation prior to speaking
- Speak into a microphone
- In-room projection is being shared virtually as well
- There are audio speakers in the room, but unmuted virtual commentators may not be immediately connected. Please be patient.
- In-person participants are discouraged from joining the virtual meeting due to wireless bandwidth constraints

Virtual Attendees

- **Audio**
 - Virtual attendees are muted upon entry
 - Do not un-mute your line unless acknowledged by the hosts to do so
 - If you need to speak, please use the Raise Hand button and the moderator will enable your microphone
 - Un-mute to present your topic
- **Video**
 - We encourage you to keep your video off due to the high number of virtual participants.
 - If you do enable your video, be mindful that you are on display
 - If you are a speaker for a topic, video sharing is acceptable
- **Miscellaneous**
 - Please do not attempt to share your screen without being asked to do so by the Hosts
 - Use the chat function to ask questions
 - Our moderator will share questions throughout the presentation with the speaker to answer.
 - Be aware that chat comments sent to the Host may be seen by those in-person in addition to general chat comments.

Meeting Attendance



ASHRAE TC 9.9 Attendance Record

ASHRAE Technical Committee 9.9 - Mission Critical Facilities, Data Centers, Technology Spaces and Electronic Equipment

Meeting Attendance is tracked via a Google form. Please complete the attendance form for each meeting...

2026 Winter Attendance Form

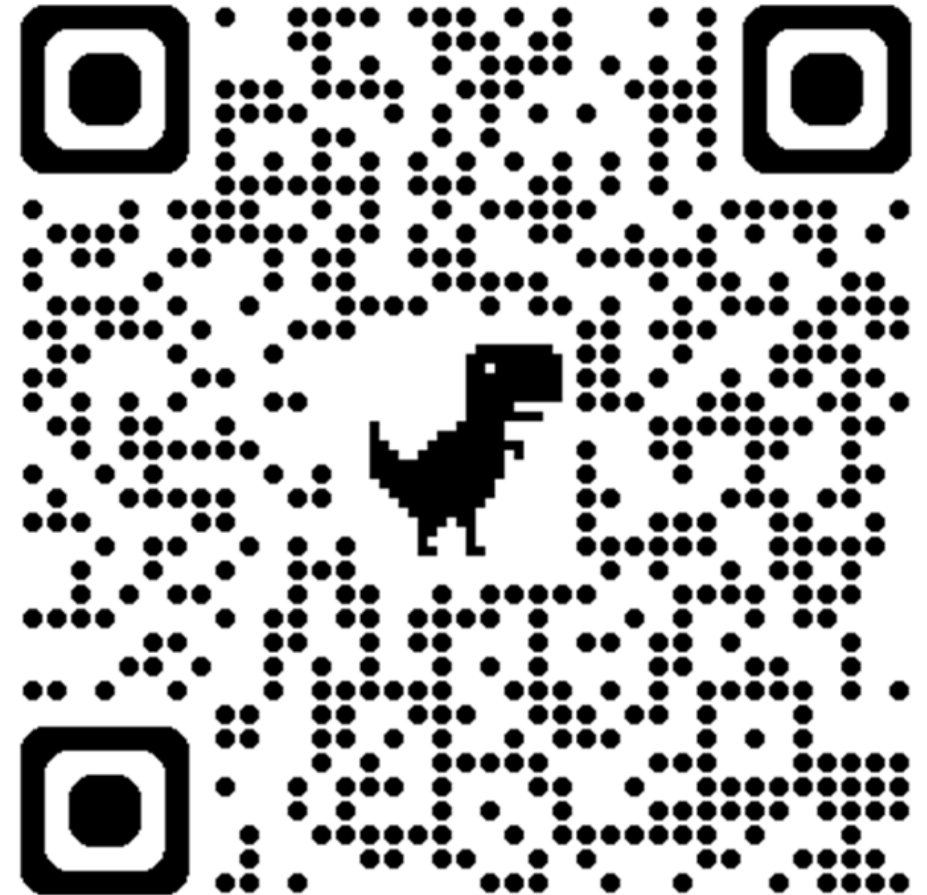

<https://forms.gle/3oAAsj5ZVHqT9f6M6>

ASHRAE Value Statement

In ASHRAE meetings, we will act with honesty, fairness, courtesy, competence, inclusiveness and respect for others, which exemplify our core values of excellence, commitment, integrity, collaboration, volunteerism and diversity, and shall avoid all real or perceived conflicts of interest. Our culture is one of inclusiveness, acknowledging the inherent value and dignity of each individual. We celebrate diverse and inclusive communities, understanding that doing so fuels better, more creative and more thoughtful ideas, solutions and strategies for the Society and the communities our Society serves. We respect and welcome all.

Code of Ethics - <https://www.ashrae.org/about/governance/code-of-ethics>

Core Values - <https://www.ashrae.org/about/ashrae-s-core-values>

Diversity Statement - <https://www.ashrae.org/about/diversity-equity-and-inclusion-dei>

Antitrust Policy - <https://youtu.be/ykisOzjHyZM>

Workshops Meeting

- New meeting format for Sunday...
 - Shifting the traditional long discussions for Handbook, Programs, & Research from Sunday to the main meeting on Monday
 - Dedicate time for face-to-face discussions & group work on Sunday
- Start with some working group “primers”
- Break into parallel tracks
 - **Track 1: Datacom Encyclopedia**
 - **Track 2: Handbook**
 - **Track 3: Programs**
 - **Track 4: Research**
- If your track ends early, please feel free to join another track

- Version 2 of the Datacom Encyclopedia published on 10/13/2025, incorporating *Thermal Guidelines, Liquid Cooling, Design Considerations, and IT Equipment Design*.
- Goal of today’s workshop is to solicit volunteers who want to serve as content managers and/or content editors for 2026. Establish roadmap for 2026.
- Topic Management Responsibilities
 - Content Manager:
 - Provide overall project management for a topic
 - Source content editors & developers
 - Determine proper structure for topic and integration of each subtopic
 - Content Editor:
 - Provide overall editing of the subtopics to ensure consistency in-line with framework provided
 - Source content editors & developers and manage the process

March 2024	TC 9.9 Datacom Encyclopedia is launched with updates to Design Considerations for Datacom Equipment Centers & Liquid Cooling Guidelines for Datacom Equipment Centers.
August 2024	Process is introduced and approved by TC 9.9 for providing content updates and version tracking.
October 2025	TC 9.9 Datacom Encyclopedia is transitioned to an encyclopedia format that incorporates Thermal Guidelines for Datacom Equipment Centers, Design Considerations for Datacom Equipment Centers
1H2026	Formalize Encyclopedia Leadership and work to incorporate existing material from other Datacom Series book, white papers, and technology briefs.
End 2026	Transition of all Datacom Series books into Encyclopedia
On-going	Quarterly updates, approved by TC 9.9, begin.

We are now at the END of our revision cycle for the Applications Handbook!

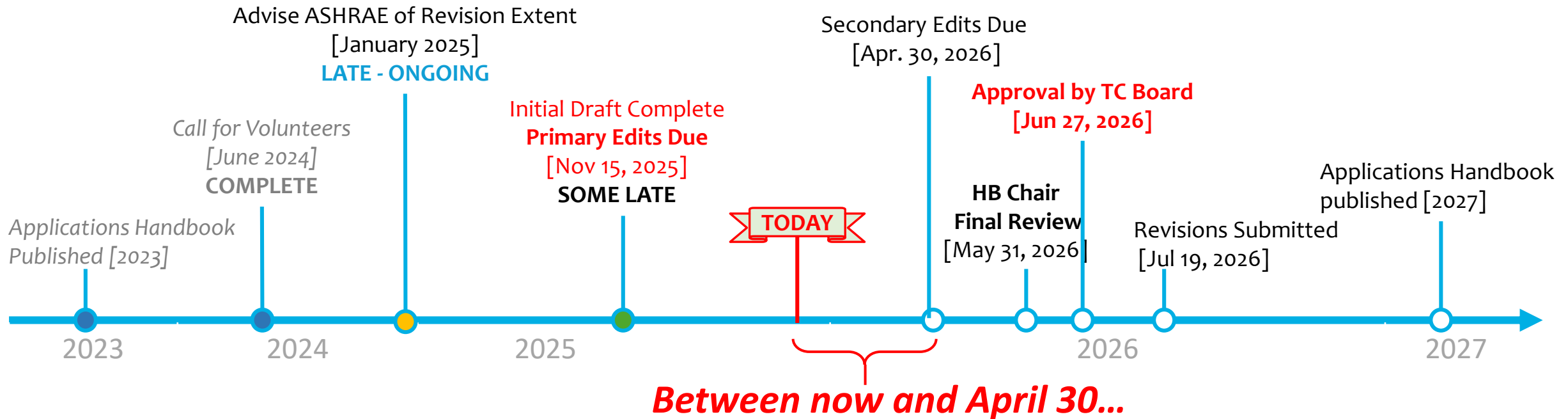

- 1. <TODAY> Get volunteers for unassigned topics Work Session!!**
- 2. Secondary Section Reviews Complete (One Assignment Remaining)**
- 3. References and Bibliography Review & Revisions (Need Volunteers)**

Unassigned Topics

ID	Section	Topic
7	2.2 Datacom Equipment Racks	With Fig. 2 & # (ID 111 & 112)
37	3.1 General Considerations	Lighting
52	3.2 Air Cooling	Row-Based Cooling
65	3.3 Liquid Cooling	Piping Distribution System (W/ Fig. 16 – ID 125))
97	4. Resources	ANSI/TIA Std. 942-B
98	4. Resources	ANSI/BICSI Std. 002
99	4. Resources	ANSI/ASHRAE Std. 202
100	4. Resources	ASHRAE Guideline 0
101	4. Resources	BICSI 009
102	4. Resources	The Green Grid White Paper #79
103	4. Resources	The Green Grid White Paper #68
105	4. Resource	ISO/IEC 22237 Series
106	4. Resources	European Commission - The European Code of Conduct for Energy Efficiency in DCs
107	References	-
108	Bibliography	-

Please advise Bob McFarlane and Jonell Watson
rmcfarlane@smwillc.com | Jonell@hudson-trading.com

- **Fundamentals and Applications Track**
 - Technical alert seminar (recent published)
 - IT load Power trend and cooling requirement
- **HVAC&R Systems and Equipment Track**
 - Modular Electrical Room Design in Data Centers (seeking speakers)
 - TCS Loop CX best practice
 - CDU testing using SSPC 127 - Dave McGlocklin
 - TCS/FWS chilled water loop Flow Velocity or Fluid quality Monitoring & Maintenance
 - TCS Commissioning (Pre-ITE and Post-ITE)
 - Debate (90.1 scope requirement on TCS Loop: whether this should be exempted – John Gross

- **Research Summit**

- OCP & ASHRAE TC 9.9 Collaboration - Status, Workstreams, & Path Forward
- ARPA-E Cool Chip program update

- **Workforce Development**

- Data center engineering workforce development
- Datacom Online Encyclopedia update
- Ai Factory workforce training

- **Building decarbonization**

- Data Center decarbonization best practice

TRP-1913 - *Study of the Corrosion Impact on Information Technology Equipment in Data Centers Located in Coastal Regions with High Sea Salt Concentration* (Chris Muller)

Research was awarded in Summer 2025
Project underway.

TRP-1972 - *Data Center Direct-to-Chip Liquid Cooling Resiliency – Failure Modes and IT Throttling Impacts* (Tom Davidson)

Bids have been received and being reviewed by the PES. Expect vote on the selected bidder during executive session on Monday.

WS-1956 - *Compact CFD Modeling Guidance for Thin Flow Resistances*
(Jim Van Gilder, et al.)

TC4.10 is the cognizant TC, TC9.9 is a Co-Sponsor
Difficulty getting buy-off from RAC. May drop.

RTAR ##### – *Effective Dispersal Volume Dynamic Reaching Height for Flammable Refrigerant Releases* (Rick Pavlak)

Submitted to RAC for review in December 2025

RTAR ##### – *Guidelines for Data Center External Dispersion Modeling* (Brad Cochran)

Uploaded to RTAR Portal

Co-Sponsored by TC4.3 and TC4.10 (Voting on During Main Meetings)

Need vote from TC9.9

RTAR in Development – *Flow Velocity Limits for Erosion Control* (Mark Steinke)

Proposed RTAR - *Digital twin for data center environments for liquid cooling and how that might be able to be developed* (Ali Heydari)

Workgroups Now in Progress

ASHRAE TC 9.9 Website



<https://tc0909.ashraetcs.org>

2026 Winter Attendance Form

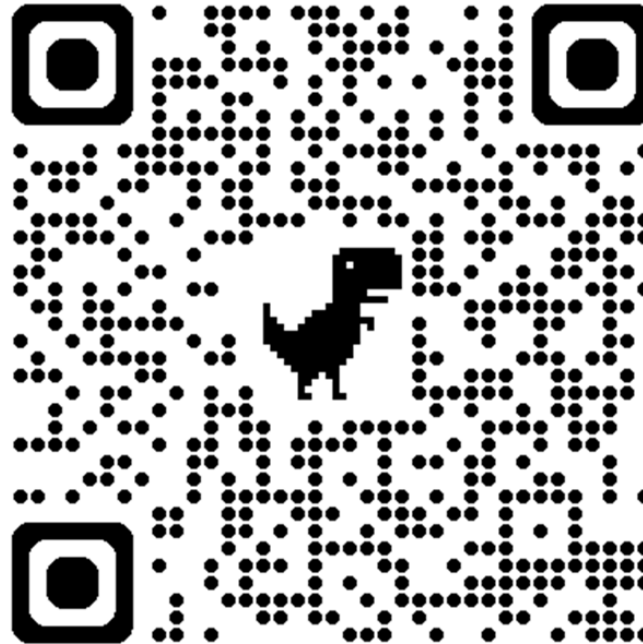

<https://forms.gle/3oAAj5ZVHqT9f6M6>

Datacom Encyclopedia

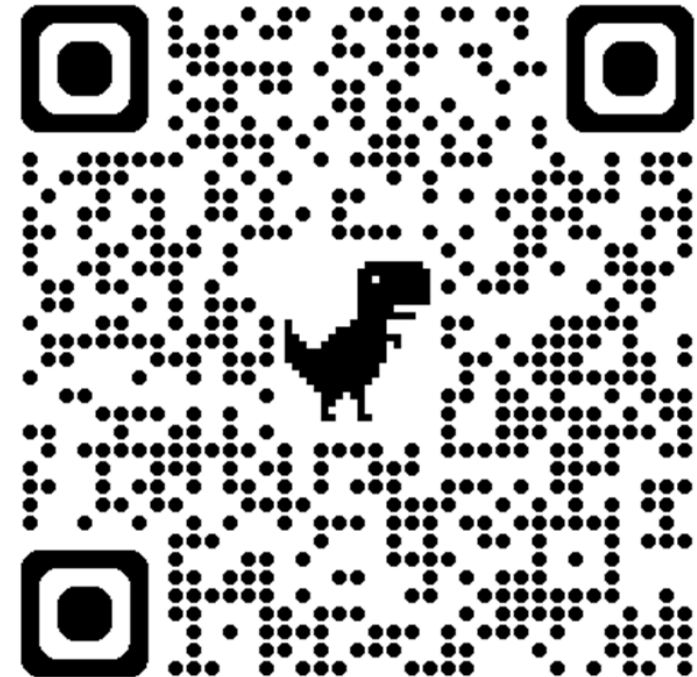

<https://datacom.ashrae.org>



Mission Critical Facilities, Data Centers, Technology Spaces and Electronic Equipment

2026 ASHRAE Winter Conference

Las Vegas, NV

Main TC 9.9 Committee Meeting

Monday February 2, 2026

Hybrid In-Person / Virtual

Welcome to the...

ASHRAE TC 9.9 Subcommittee

Hybrid In-Person/Virtual Meeting

High Level Agenda

- Welcome
- Hybrid Meeting Etiquette
- Introductions
- Title, Purpose, & Scope
- Membership
- Liaison Reports
- Subcommittee Updates
- Workgroup Sessions

Meeting Organizers

Meeting Host: Mark Steinke - *Chair*

- Organize the meeting content
- Introduce topics
- Moderate discussions
- Manage screen-sharing and in-person presentation

Virtual Host: John Gross - *Vice Chair*

- Monitor the chat for questions and comments
- Mute and Unmute Virtual Participants
- Manage discussions and voting

Virtual Co-Host: Chris Campbell - *Secretary*

- Monitor time and keep the meeting on schedule
- Record the event
- Produce meeting minutes
- Respond to audio problems
- Add the attendance link to the chat

Agenda

Section	Topic	Time	Presenter
Welcome	Welcome, Agenda, & Meeting Etiquette	10	Mark Steinke
Introductions	TC 9.9 T.P.S., Structure, New Officers, Subcommittee Chairs, Voting Members, & In-Person Attendees Introductions	35	Mark Steinke
TC 9.9 Membership	Review of Membership Statistics	10	John Groenewold
TC 9.9 Activity	Recorded Votes Website Updates	15	Mark Steinke Ecton English
Liaison Reports	Standard 90.1 Standard 90.4 OCP	25	Rick Pavlak Marcus Hassen Matt Koukl
SSPC127 Addn. B	Release Review	10	David McGlocklin
Handbook Subcommittee	Updates on Chapter Progress	15	Robert McFarlane Jonell Watson
Programs Subcommittee	2026 Winter & Summer Meetings Other Updates	15	Eric Yang
BREAK		20	
Special Presentation	RP1890 Presentation	20	George Land
Standards Subcommittee	Updates	5	Rick Pavlak
International Subcommittee	Updates LinkedIn Statistics	5	Paul Finch
Publications Subcommittee	Encyclopedia Updates Tech Briefs	15	Don Beaty
Research Subcommittee	Updates RTARs	15	Brad Cochran
IT Manufacturers Subcommittee	Updates	30	Dustin Demetriou

Total Time: 245 Minutes

Housekeeping & Meeting Etiquette

General Meeting Etiquette

- Individuals should state their name & affiliation prior to speaking
- Speak into a microphone
- In-room projection is being shared virtually as well
- There are audio speakers in the room, but unmuted virtual commentators may not be immediately connected. Please be patient.
- In-person participants are discouraged from joining the virtual meeting due to wireless bandwidth constraints

Virtual Attendees

- **Audio**
 - Virtual attendees are muted upon entry
 - Do not un-mute your line unless acknowledged by the hosts to do so
 - If you need to speak, please use the Raise Hand button and the moderator will enable your microphone
 - Un-mute to present your topic
- **Video**
 - We encourage you to keep your video off due to the high number of virtual participants.
 - If you do enable your video, be mindful that you are on display
 - If you are a speaker for a topic, video sharing is acceptable
- **Miscellaneous**
 - Please do not attempt to share your screen without being asked to do so by the Hosts
 - Use the chat function to ask questions
 - Our moderator will share questions throughout the presentation with the speaker to answer.
 - Be aware that chat comments sent to the Host may be seen by those in-person in addition to general chat comments.

Meeting Attendance



ASHRAE TC 9.9 Attendance Record

ASHRAE Technical Committee 9.9 - Mission Critical Facilities, Data Centers, Technology Spaces and Electronic Equipment

Meeting Attendance is tracked via a Google form. Please complete the attendance form for each meeting...

2026 Winter Attendance Form

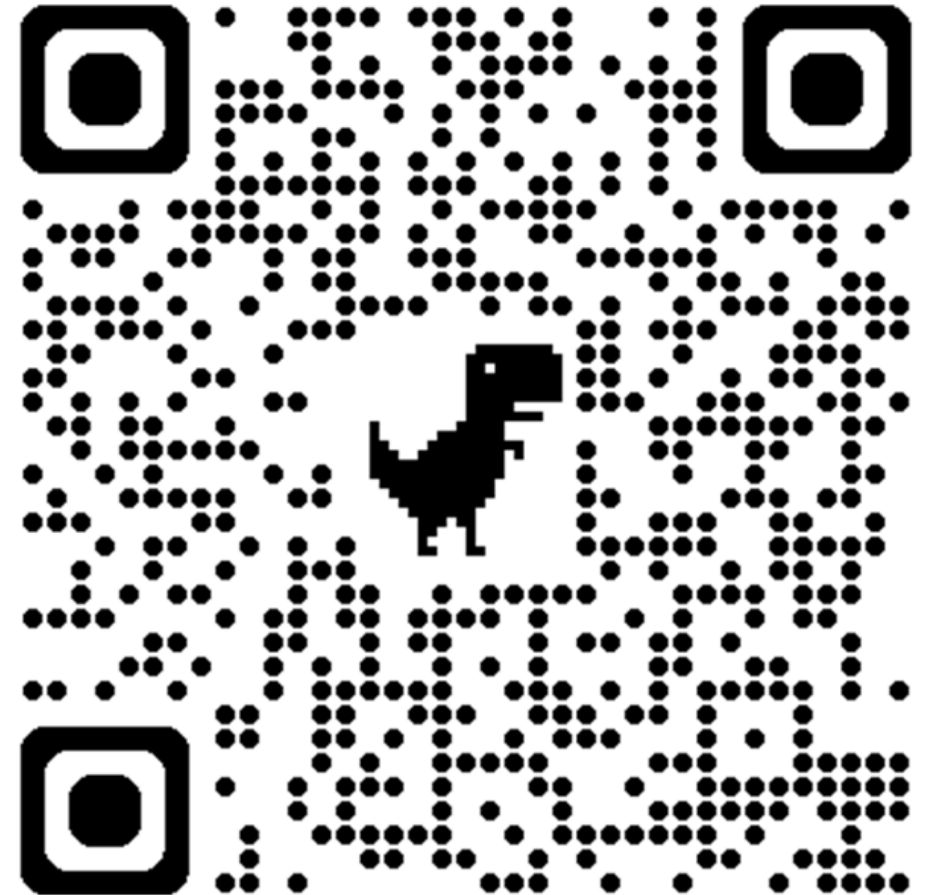

<https://forms.gle/3oAAsj5ZVHqT9f6M6>

ASHRAE Value Statement

In ASHRAE meetings, we will act with honesty, fairness, courtesy, competence, inclusiveness and respect for others, which exemplify our core values of excellence, commitment, integrity, collaboration, volunteerism and diversity, and shall avoid all real or perceived conflicts of interest. Our culture is one of inclusiveness, acknowledging the inherent value and dignity of each individual. We celebrate diverse and inclusive communities, understanding that doing so fuels better, more creative and more thoughtful ideas, solutions and strategies for the Society and the communities our Society serves. We respect and welcome all.

Code of Ethics - <https://www.ashrae.org/about/governance/code-of-ethics>

Core Values - <https://www.ashrae.org/about/ashrae-s-core-values>

Diversity Statement - <https://www.ashrae.org/about/diversity-equity-and-inclusion-dei>

Antitrust Policy - <https://youtu.be/ykisOzjHyZM>

How is ASHRAE Structured?

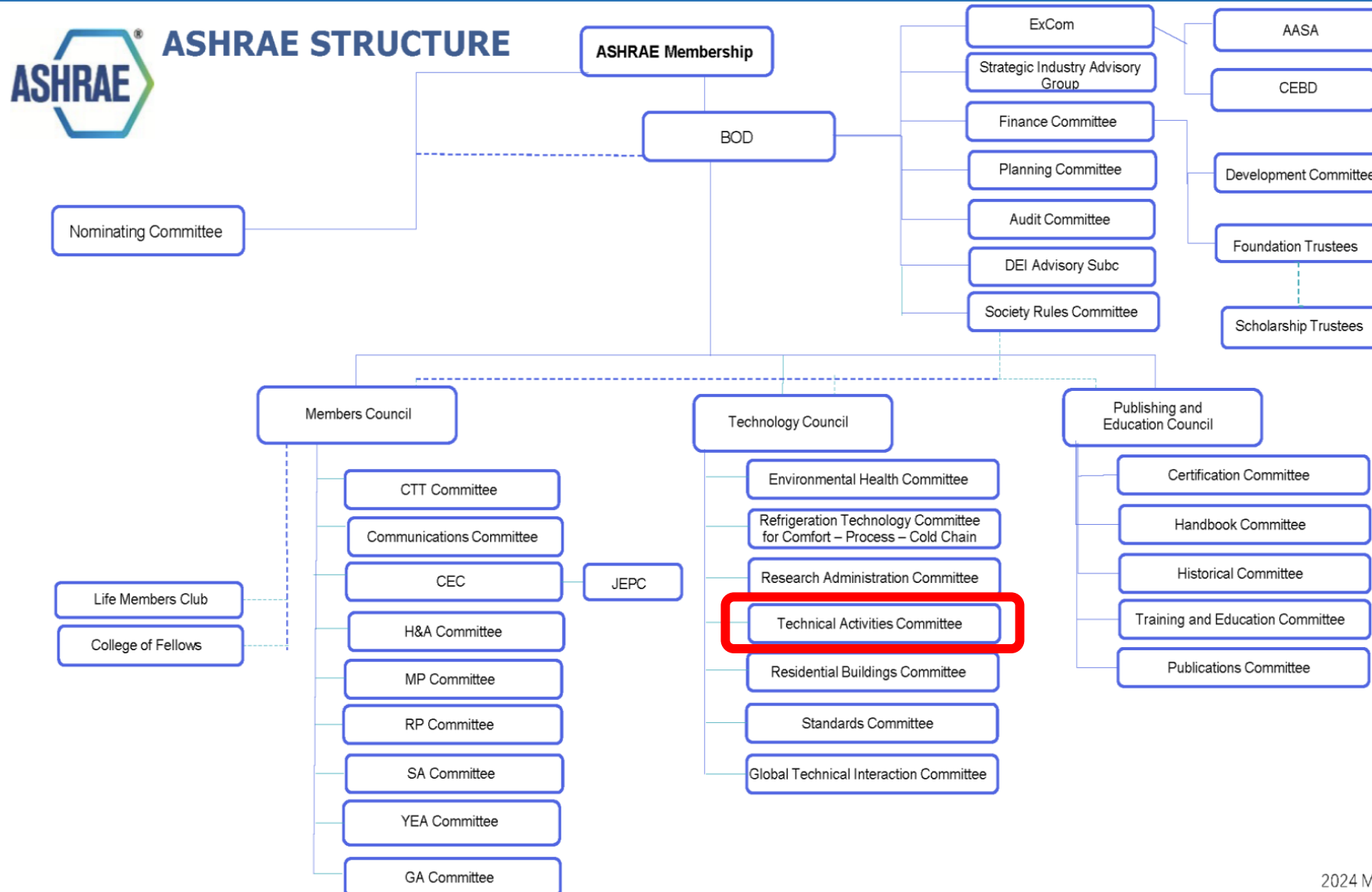

ASHRAE Technical Committee's Purpose

- ASHRAE Technical Committees consist of people who have a recognized proficiency in a specific field of interest
- The TCs are responsible for...
 - Preparing the text of ASHRAE Handbook chapters
 - Originating, coordinating, and supervising Society-sponsored research projects
 - Presenting programs at ASHRAE meetings
 - Reviewing technical papers
 - Evaluating the need for standards
 - Advising the Society on all aspects of the technology it embraces

Liquid to Air

- Mainstream computing rapid change from LIQUID cooling to AIR cooling

Air Cooling

- Data center industry had LIMITED air-cooling experience & guidelines

IT Hardware manufacturers

- Hardware failure concern due to data center inadequacies

Industry Disruption

- Dotcom boom & bust impact
- Bipolar to CMOS

Bottomline

- Telecom / Data Center CHAOS

TC 9.9 Challenge

- Building Design / Construction / Operations Industry
- Hardware Industry & Data Center Niche Industry
- Rapid Growth Impact & Speed to Market yet Standards Level Credibility

TC 9.9 Solution

- Step 1
 - Transition IT manufacturers from proprietary to common thermal guidelines
- Step 2
 - Rapid publication of unbiased, vendor neutral content in layman's terms
- Step 3
 - Rapidly become globally known as the trusted source

TC 9.9 Publications

- Phase 1 – New DATACOM book / year
- Phase 2 – New books plus book revisions
- Phase 3a – Convert / consolidate published books to Online Encyclopedia
- Phase 3b – Transition from book level revisions to snippet level rapid revisions

TC 9.9 Pillars

1. IT hardware manufacturers develop & agree on current & future hardware needs
2. Cross section of manufacturers, users, designers, constructors, commissioning agents translate hardware needs into layman's terms
3. Remain unbiased, vendor neutral, system agnostic
4. Highlight useful life infrastructure discrepancy (IT vs Cooling vs, Power vs Bldg)

Over Confidence in a rapid changing environment

- It is better to be open minded “draw on” instead of “build on” experience

Speed

- Delayed information risk is high
- Reduce level of detail to achieve the critical need for speed; (further detail can follow)

Remain Agnostic

- We do not recommend systems / architecture
- We provide guidance on how to implement a selected system / architecture

TITLE

- **Mission Critical Facilities, Data Centers, Technology Spaces and Electronic Equipment**

PURPOSE

- To be recognized by ALL areas of the datacom industry as the UNBIASED engineering leader in HVAC and an effective provider of technical datacom information.

SCOPE

- All things datacom facilities: datacom refers to data processing and communication facilities. It includes rooms or closets used for communication, computers, or electronic equipment

Who are TC 9.9 Members?

Participants

- TC 9.9 is the largest ASHRAE TC
- Most active TC with over 700+ members

Representatives

- Producers of Datacom Equipment: computing hardware, software, and services
- Producers of Facility Equipment: HVAC, software, DCIM, rack solutions
- Users of Datacom Equipment: facility owners, operators, managers
- Many different segments
 - Government agencies, enterprise, telco, utilities, consultants, academia, testing laboratories...

Industry Volunteers Provide the Expertise

- Manufacturers, consultants, researchers, universities, utilities, regulators, contractors, and government

Areas of Influence

- Handbook, Standards, Research, Programs
- Technical Activities: Books, White Papers & Tech Briefs, Encyclopedia, Education...

How is ASHRAE TC 9.9 Structured?

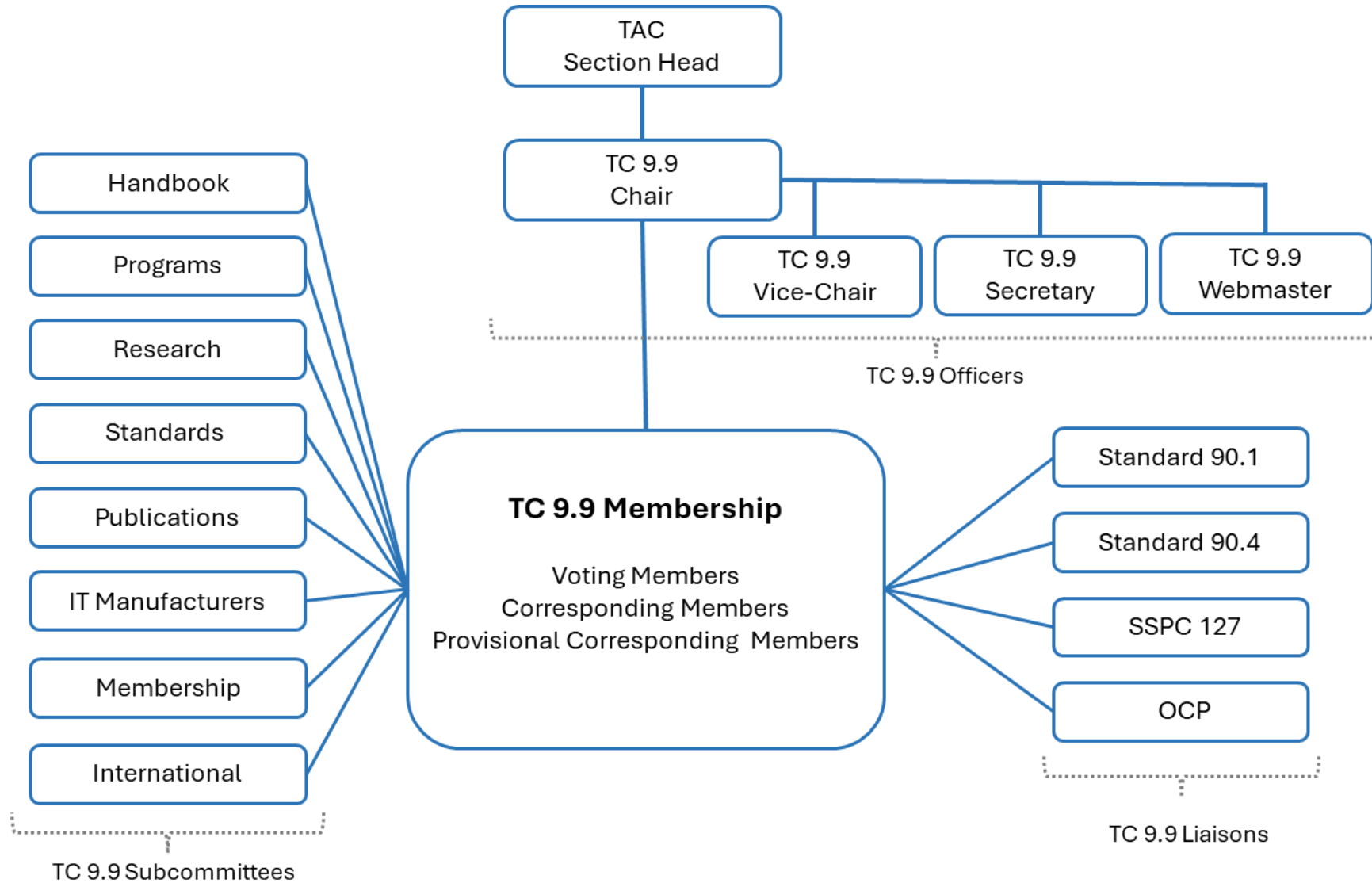

ASHRAE TC 9.9 - Previous Chairs



Don Beaty
2005 - 2007
DLB Assoc.



Roger Schmidt
2007 - 2009
IBM



Fred Stack
2009 - 2011
Liebert



Jack Glass
2011 - 2013
Citigroup



Dave Quirk
2013 - 2015
DLB Assoc.



Robin Steinbrecher
2015 - 2017
Intel Corporation



Jason Matteson
2017 - 2019
Lenovo, Vertiv



Dustin Demetriou
2019 - 2021
IBM



John Groenewold
2021 - 2023
Vantage Data Centers



Matt Koukl
2023 - 2025
Affiliated Engineers, Inc.

A Special Thank You to Matt!

- Thank you for your service to ASHRAE TC 9.9!
 - Secretary 2019 - 2020
 - Vice-Chair 2021 – 2023
 - Chair 2023 – 2025
- In your term as chair...
 - TC 9.9 updated...
 - Handbook: Applications Chapter 20
 - TC 9.9 released...
 - “Thermal Guidelines” - 5th Edition Revised & Expanded
 - Standard 90.4-2025
 - Tech Briefs and Tech Alerts
 - TC 9.9 moved from printed Datacom books to an “Online Encyclopedia” model
 - Established a Memorandum of Understanding (MoU) with OCP to foster better collaboration



Matt Koukl

TC 9.9 Chair

2023 - 2025

Affiliated Engineers, Inc.

TC 9.9 Officers

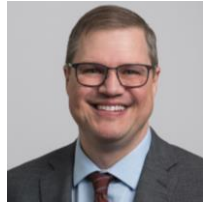

Chair

Mark Steinke
NVIDIA
TC0909@ashrae.net
TC99Chair@gmail.com



Vice-Chair

John Gross
J.M. Gross Engineering
TC0909.VCH@ashrae.net



Secretary

Chris Campbell
Vertiv
TC0909.SEC@ashrae.net



Webmaster

Ecton English
Johns Hopkins University APL
TC0909.WEB@ashrae.net

TC 9.9 Subcommittee Chairs



Handbook

Robert McFarlane
Shen Milson & Wilke, LLC
TC0909.HBK@ashrae.net



Programs

Eric Yang
Independent Data Center
Consultant
TC0909.PRO@ashrae.net



Research

Brad Cochran
CPP, Inc.
TC0909.RES@ashrae.net



Standards

Rick Pavlak
Heapy Engineering, Retired
TC0909.STD@ashrae.net



Publications

Don Beaty
DLB Assoc., Retired
Don.Beaty@Outlook.com



Membership

John Groenewold
CBRE Global Workplace Solutions
john.groenewold@cbre.com



IT Manufacturers

Dustin Demetriou
IBM
dwdemetr@us.ibm.com



International

Paul Finch
Goldfinch Digital Infrastructure Partners
paul.finch@gdip.co.uk

ASHRAE TC 9.9 - Voting Members (13)



Dustin Demetriou
IBM



Jason Matteson
nVent



Tim Shedd
Dell Technologies



Ecton English
Johns Hopkins University APL

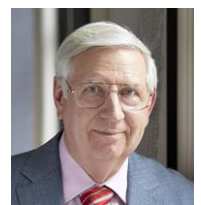

Robert McFarlane
Shen Milson & Wilke, LLC

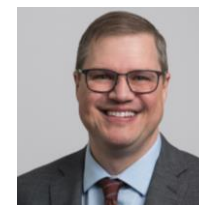

Mark Steinke
NVIDIA



Paul Finch
*Goldfinch Digital
Infrastructure Partners*



David McGlocklin
Schneider Electric



Lixia Wu
Cushman & Wakefield



Nick Gangemi
Weeks Group

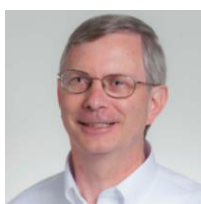

Rick Pavlak
Heapy Engineering, Retired



John Gross
J.M. Gross Engineering



Dave Quirk
DLB Assoc.

Meeting Attendee Introductions



- Only “In Person” Attendees
- Please introduce yourself and state the following
 - **Name**
 - **Business Title & Company**
 - ***TC Subcommittee Membership***
 - TC 9.9 Subcommittee Positions
 - Other Subcommittee Memberships
 - Liaison
 - ***TC 9.9 Membership Status***
 - Voting Member
 - Corresponding Member
 - Provisional Corresponding Member
 - Guest

2026 Winter Attendance Form

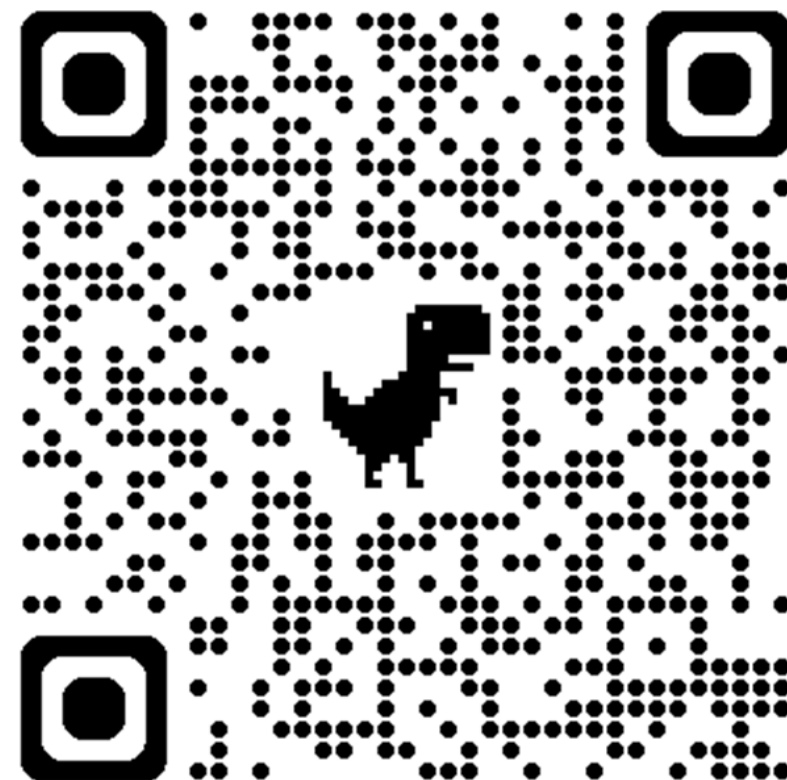

<https://forms.gle/3oAAsj5ZVHqT9f6M6>



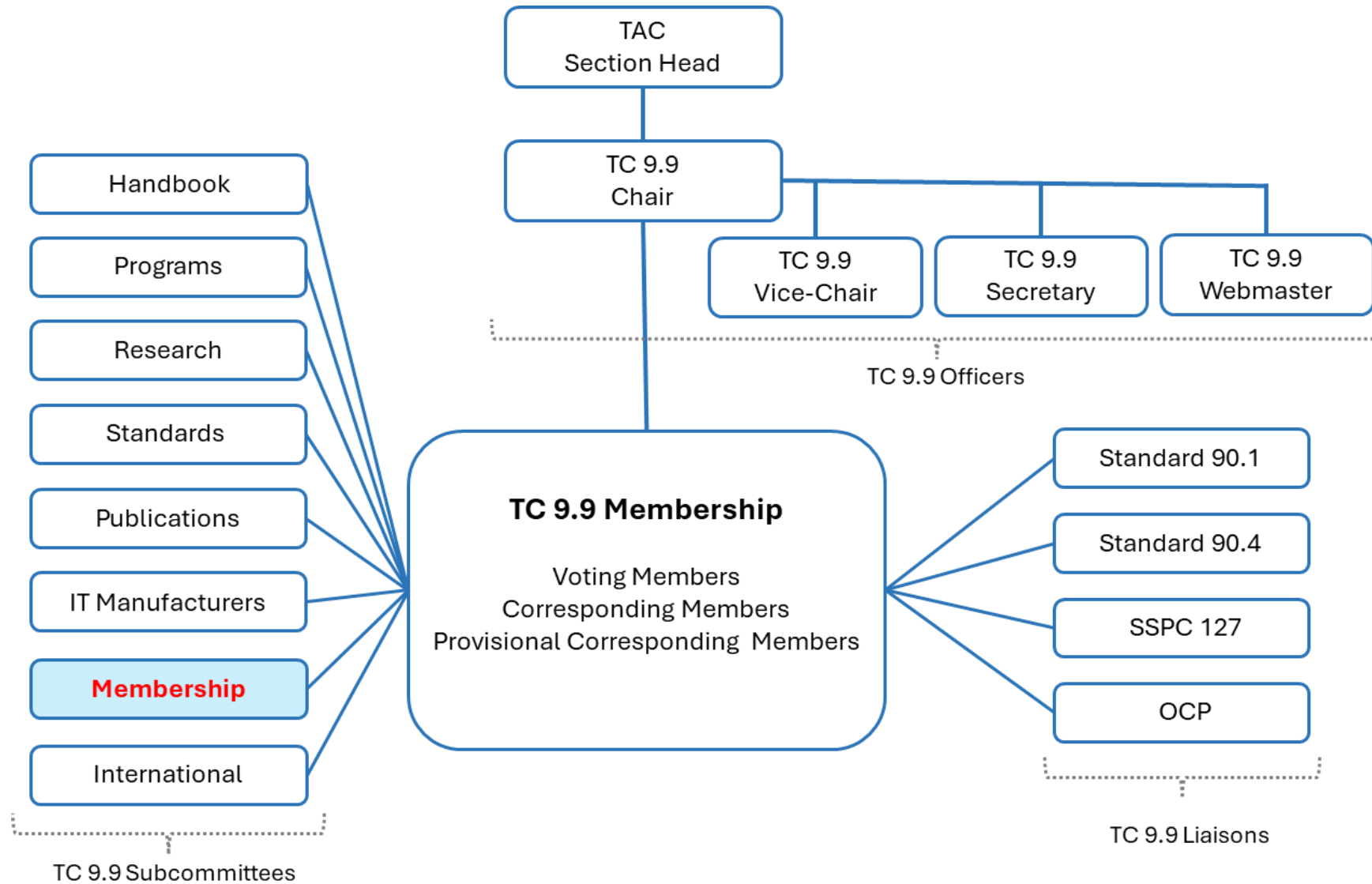











Membership Subcommittee



- **Provisional Corresponding Member (PCM)**
 - PCMs are newly registered member to the TC & serve a two (2) year term as a PCM
 - Participation in committee activities & involvement needed to become corresponding member after the two years
 - PCMs are rolled off from the roster after two years if there was no participation
 - For purposes of committee assignments and other work, PCM status does not limit an individual's active involvement in the work of the committee
- **Corresponding Member (CM)**
 - Full member of the TC
 - Expected to participate in TC activities
 - May serve as Officers, Subcommittee Chairs, or Voting members
- **Voting Member (VM)**
 - Must be a Corresponding Member
 - Serve a four (4) year term
 - Only one VM per company



TC 9.9 Membership – Roster Update

John Groenewold

Membership Type	2024 Annual Meeting	2025 Winter Meeting	2025 Annual Meeting	2026 Winter Meeting
Board, Chairs, & Liaisons	23	23 	23 	24 
Corresponding Members	365	357 	357 	406 
Provisional Corresponding Members	139	185 	259 	306 
YEA	67	69 	100 	126 
TOTAL	518	565 	639 	736 

TC 9.9 Membership – Meeting Attendance

John Groenewold

Membership Type	2024 Annual Meeting		2025 Winter Meeting		2025 Annual Meeting	
	Sunday	Monday	Sunday	Monday	Sunday	Monday
Board, Chairs, & Liaisons	11	12	7	9	11	14
Corresponding Members	22	33	18	44	26	38
Provisional Corresponding Members	16	21	28	45	17	28
YEA	2	5	1	3	4	10
TOTAL	51	71	54	101	58 	90 

- Currently 700+ members listed in the SY 25/26 Roster
- Roster updates in April for SY 26/27
- Email list is built from the Roster Contact List
- Roster decisions based upon
 - Attendance
 - Participation
 - Contact emails
- Email delivery failures are used to update the roster
- **Keep your contact email updated!**

How to Join TCs

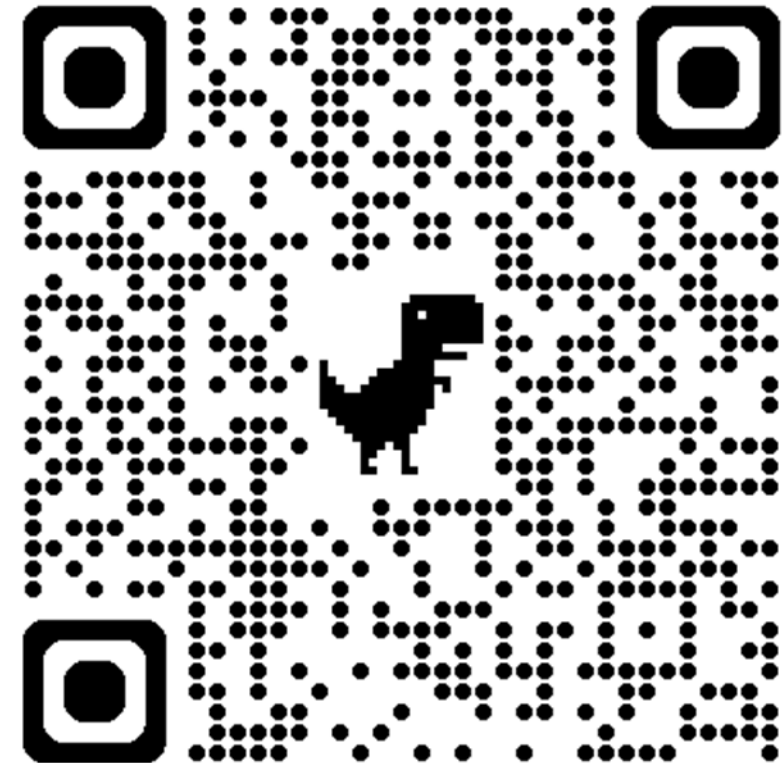

https://eweb.ashrae.org/eweb/TS_ProvisionalSignup.html

TC 9.9 Activity – Society Year 2025/2026

- Society Year runs from July 1st to June 30th
 - SY 25/26 (July 1, 2025 – June 30, 2026)
- Installed new officers
 - Chair: Mark Steinke
 - Vice-Chair: John Gross
 - Secretary: Chris Campbell
- Installed new subcommittee chair
 - International: Paul Finch
- Installed new liaison
 - OCP: Matt Koukl
- Votes Held
 - SY 25/26 Five (5)
- Updates to Standard 90.4-2025
- Released Datacom Encyclopedia V2
- Begin quarterly Encyclopedia updates (4Q25)

Votes – SY 25/26

- **Vote 1**
 - Discontinuing Datacom Series printed books?
 - Results: **Passed** (2/3 met)
- **Vote 2**
 - Proposed TC 9.9 RTAR - Effective Refrigerant Dispersal Volume
 - Results: **Passed** (2/3 met)
- **Vote 3**
 - Approval of 2024 Winter Minutes (Chicago), 2024 Annual Minutes (Indy), & 2025 Winter Minutes (Orlando)
 - Results: **Passed** (1/2 met)
- **Vote 4**
 - Approval of the Draft 2025 Annual Meeting Minutes – Phoenix
 - Results: **Passed** (1/2 met)
- **Vote 5**
 - Approval of 4Q2025 Quarterly Encyclopedia Updates
 - Results: **Passed** (2/3 met)

Do you approve discontinuing Datacom Series printed books?
12 responses

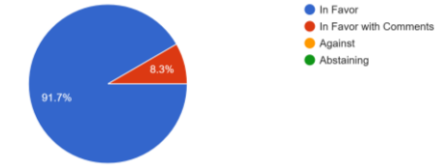

Vote 1

Do you approve submission of the Proposed RTAR including co-sponsorship with SSPC 15?
11 responses



Vote 2

Do you approve drafts of the 2024 Winter Minutes (Chicago), 2024 Annual Minutes (Indy), & 2025 Winter Minutes (Orlando)?
10 responses

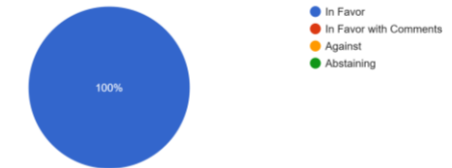

Vote 3

Do you approve drafts of the 2025 Annual Minutes - Phoenix?
13 responses

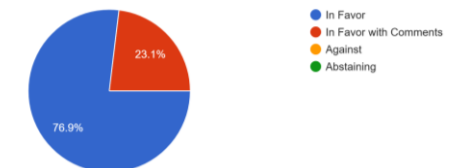

Vote 4

Do you approve of the 4Q2025 Quarterly Encyclopedia Updates ?
13 responses

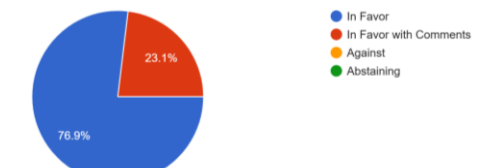

Vote 5

ASHRAE TC 9.9 - Publication Timeline (2004 – 2015)

Datacom Books, Encyclopedia

**TC 9.9
Created**

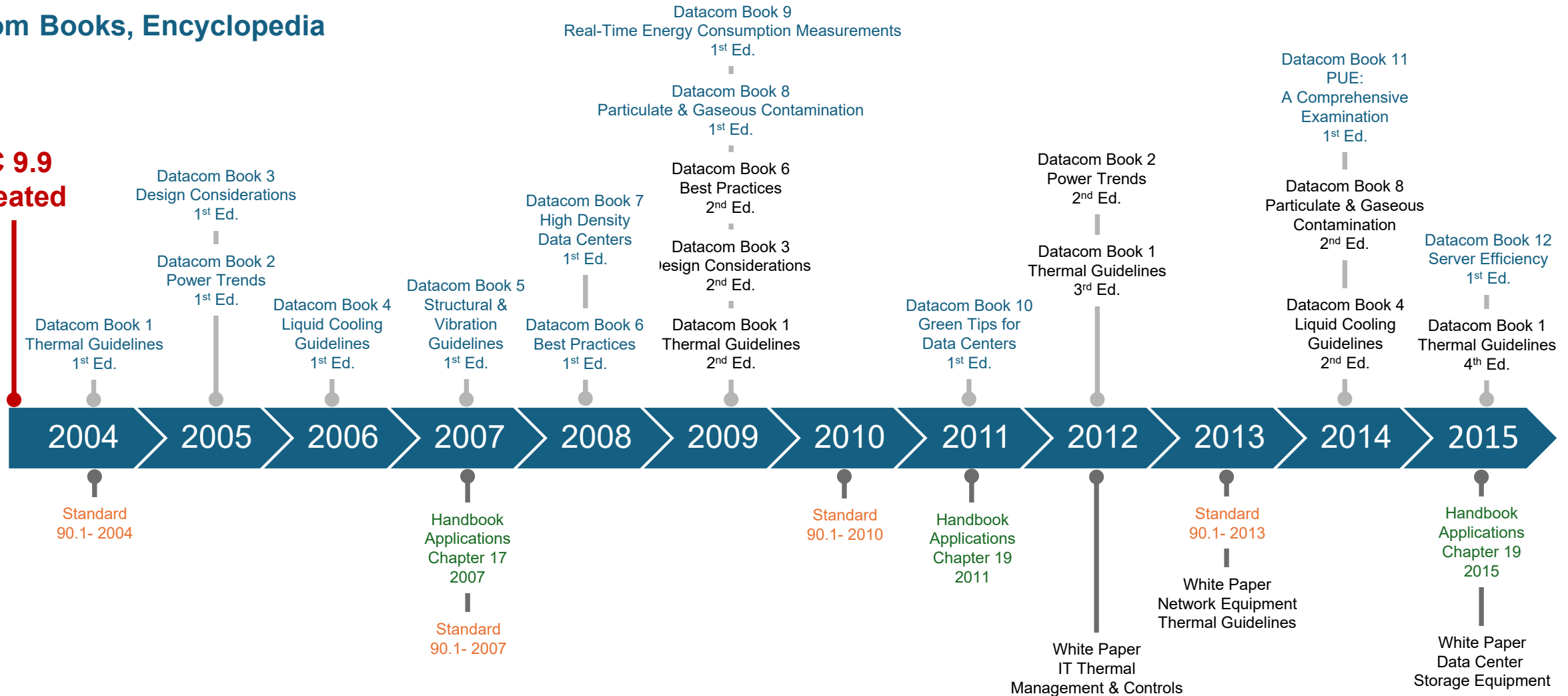

ASHRAE TC 9.9 - Publication Timeline (2016 – Present)

Datacom Books, Encyclopedia

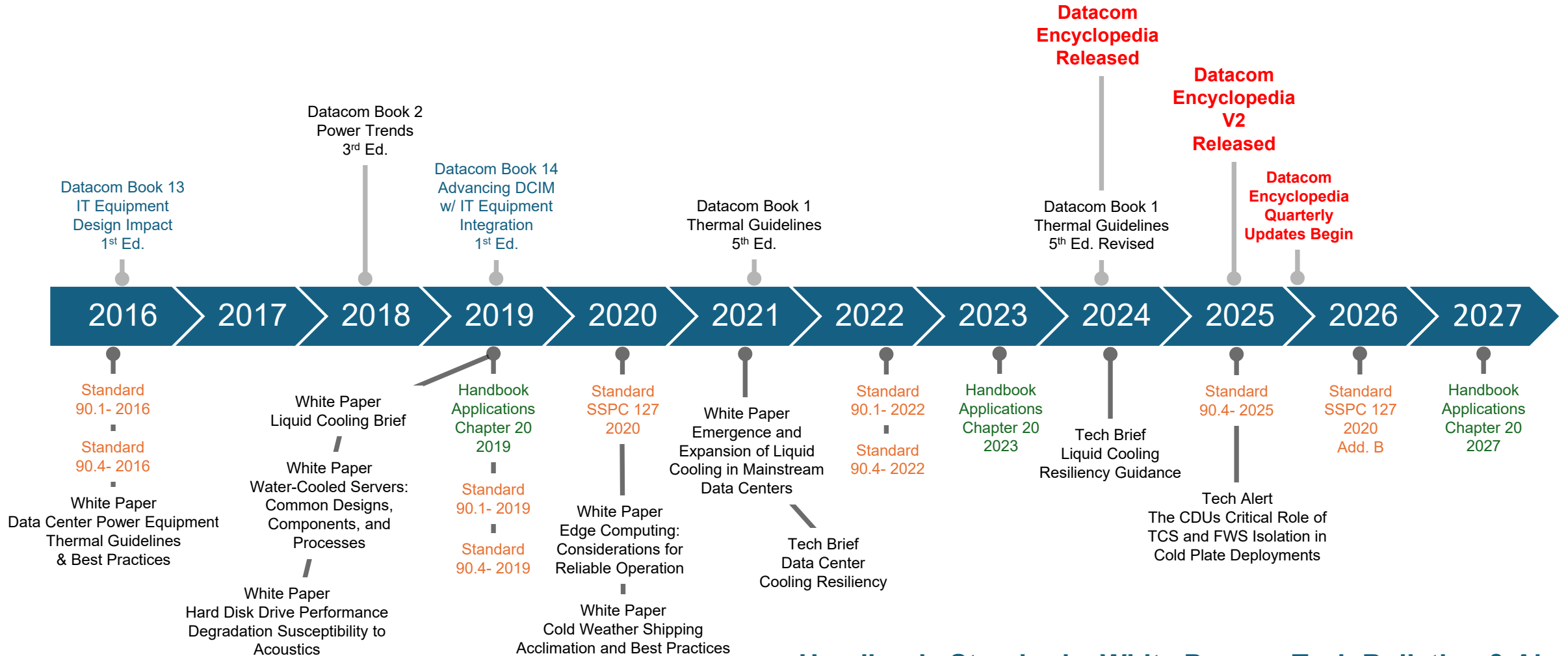

Views by Page title and screen name over time

10 June 2025 - 26 January 2026

Day ▼

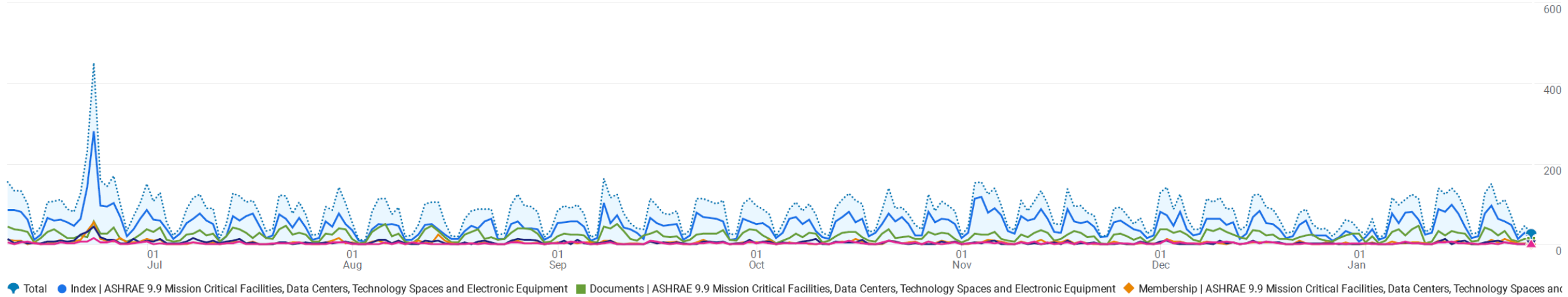

Plot rows		Q 9.9		Rows per page: 10		Go to: 1		1-10 of 120	
<input type="checkbox"/>	Page title and screen name	Views	Active users	Views per active user	Average engagement time per active user	Event count	Key events	Total revenue	
<input type="checkbox"/>						All events	All events		
<input checked="" type="checkbox"/>	Total	18,931 19.61% of total	10,549 21.51% of total	1.79 Avg -8.83%	35s Avg +13.34%	64,126 20.04% of total	0.00		\$0.00
<input checked="" type="checkbox"/>	1 Index ASHRAE 9.9 Mission Critical Facilities, Data Centers, Technology Spaces and Electronic Equipment	11,180 (59.06%)	7,514 (71.23%)	1.49	28s	38,871 (60.62%)	0.00 (-)		\$0.00 (-)
<input checked="" type="checkbox"/>	2 Documents ASHRAE 9.9 Mission Critical Facilities, Data Centers, Technology Spaces and Electronic Equipment	5,079 (26.83%)	4,084 (38.71%)	1.24	19s	16,405 (25.58%)	0.00 (-)		\$0.00 (-)
<input checked="" type="checkbox"/>	3 Membership ASHRAE 9.9 Mission Critical Facilities, Data Centers, Technology Spaces and Electronic Equipment	1,042 (5.5%)	643 (6.1%)	1.62	49s	2,965 (4.62%)	0.00 (-)		\$0.00 (-)
<input checked="" type="checkbox"/>	4 Meetings ASHRAE 9.9 Mission Critical Facilities, Data Centers, Technology Spaces and Electronic Equipment	1,011 (5.34%)	772 (7.32%)	1.31	17s	2,979 (4.65%)	0.00 (-)		\$0.00 (-)
<input checked="" type="checkbox"/>	5 Functions ASHRAE 9.9 Mission Critical Facilities, Data Centers, Technology Spaces and Electronic Equipment	566 (2.99%)	451 (4.28%)	1.25	26s	1,623 (2.53%)	0.00 (-)		\$0.00 (-)

^ Datacom Encyclopedia Navigation

Click on the TOPIC that best meets your need:



Facility Design Considerations

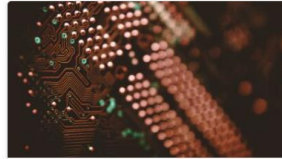

Environmental Guidelines



Cooling Technologies



Energy Efficiency



ITE Design Considerations



Everything Else

The ASHRAE TC 9.9 Datacom Encyclopedia incorporates the former Thermal Guidelines for Datacom Equipment Centers, Design Considerations for Datacom Equipment Centers, Liquid Cooling Guidelines for Datacom Equipment Centers, and IT Equipment Design Impact on Data Center Solutions, in addition to new and updated material, in a convenient, searchable "wiki" style format.

The PDF version of the Datacom book series and the digital versions of Thermal Guidelines for Datacom Equipment Centers, Design Considerations for Datacom Equipment Centers, and Liquid Cooling Guidelines for Datacom Equipment Centers remain available via the top navigation bar.

Summer 2025 ASHRAE
Conference
448 Subscribers



^ TC 9.9 Technical Alerts



Resiliency Guidance for Cold Plate Deployments



The CDUs Critical Role of TCS and FWS Isolation in Cold Plate...

Data Centers & AI Integration Conference

- Possible New ASHRAE Topical Conference...
- Joint effort between TC 9.9 & SSPC 90.4
 - Chair – Mark Steinke (TC 9.9 Chair)
 - Vice-Chair – Marcus Hassen (SSPC 90.4 Chair)
- CEC ExCom Approved Topical Conference!
- December 2026 or March 2027. Location TBD
- Steering committee formed & topics being discussed
- We'll need TC 9.9 & SSPC 90.4 support!
 - Content generation -> talks & presentations
 - Attendance
 - Raise awareness

Possible Topics...

- The Shape of the Emerging AI Ecosystem
- AI Impacts on Data Center Architecture, Design, and Siting - New Design and Commissioning Paradigms
- Attuning Data Centers with the Needs of the Communities in Which They Operate
- Power Constraints and the era of grid instability
- Sustainability and Carbon Accounting for AI Compute Facilities
- AI and next level automation in the Data Center
- Shifting Resiliency Challenges in the age of AI
- Thermal Management and Next Generation Cooling Strategies
- AI Driven Data Center Energy Optimization
- The New Workforce Readiness: Skills, Training, and Operational Models
- AI Safety, Data Governance, and Ethical Deployment
- Electrical Infrastructure Challenges for AI Intensive Workloads
- Controls Integration: Bridging BMS, EPMS, Digital Twins and AI Systems
- Reliability Engineering in AI Powered Data Centers

TC 9.9 Activity – How to Get Involved???

- Check out the TC 9.9 Website
 - Looking into creating an “Activity Section” or “Activity List” of some type
 - Active items such as Handbook work, Standards work, Research projects, Encyclopedia work, other items
- Reach out individually
 - Added email contact for all Officers & Subcommittee Chairs
 - They should be able to direct you to the right folks

ASHRAE TC 9.9 Website

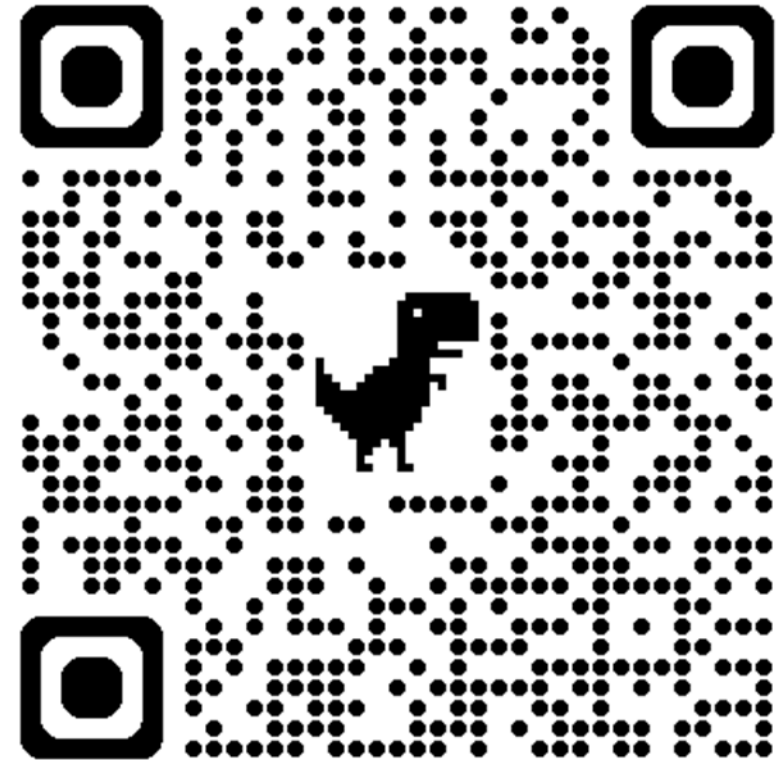

<https://tc0909.ashraetcs.org>

Standards Subcommittee

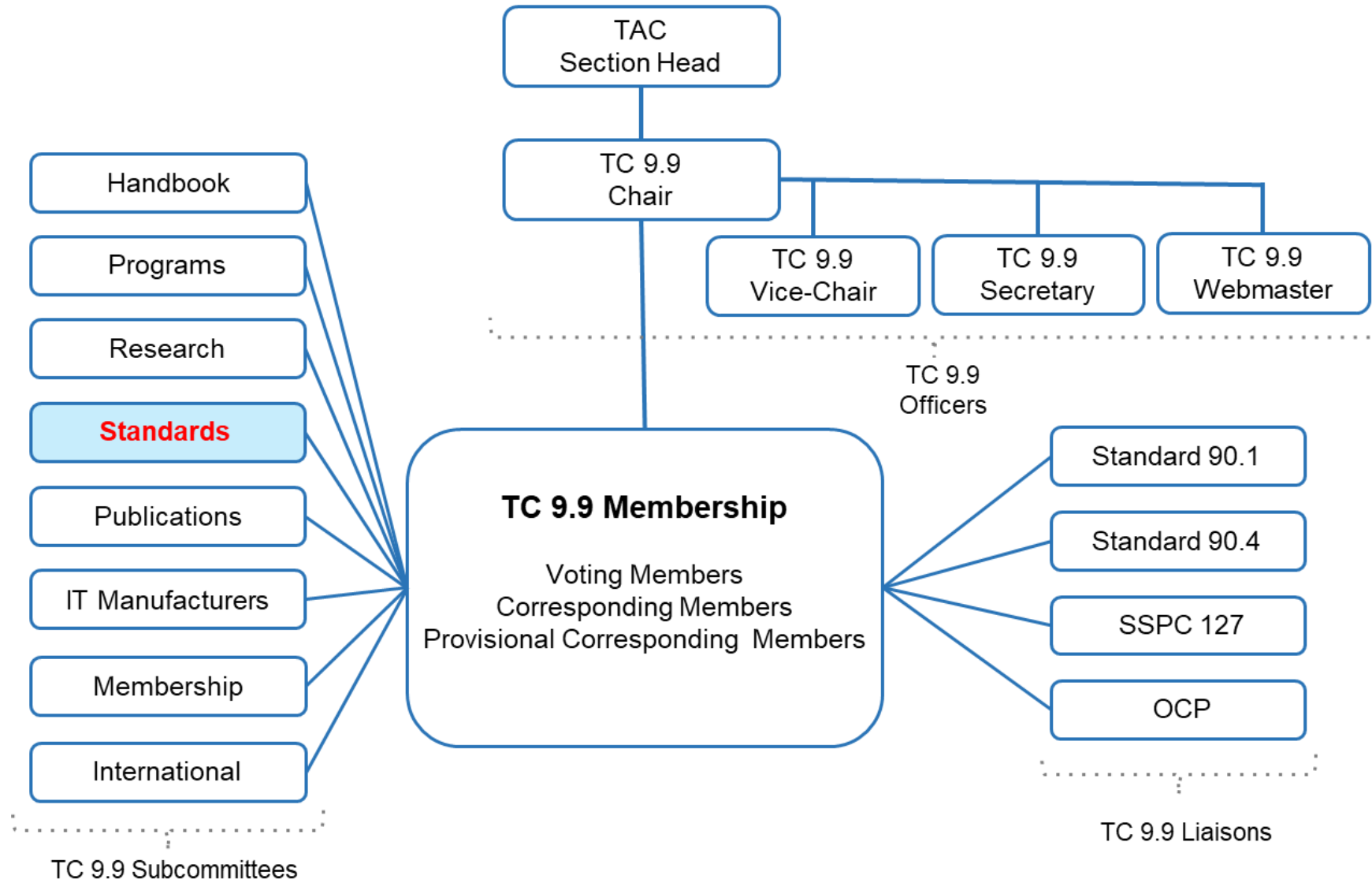

Liaison Reports

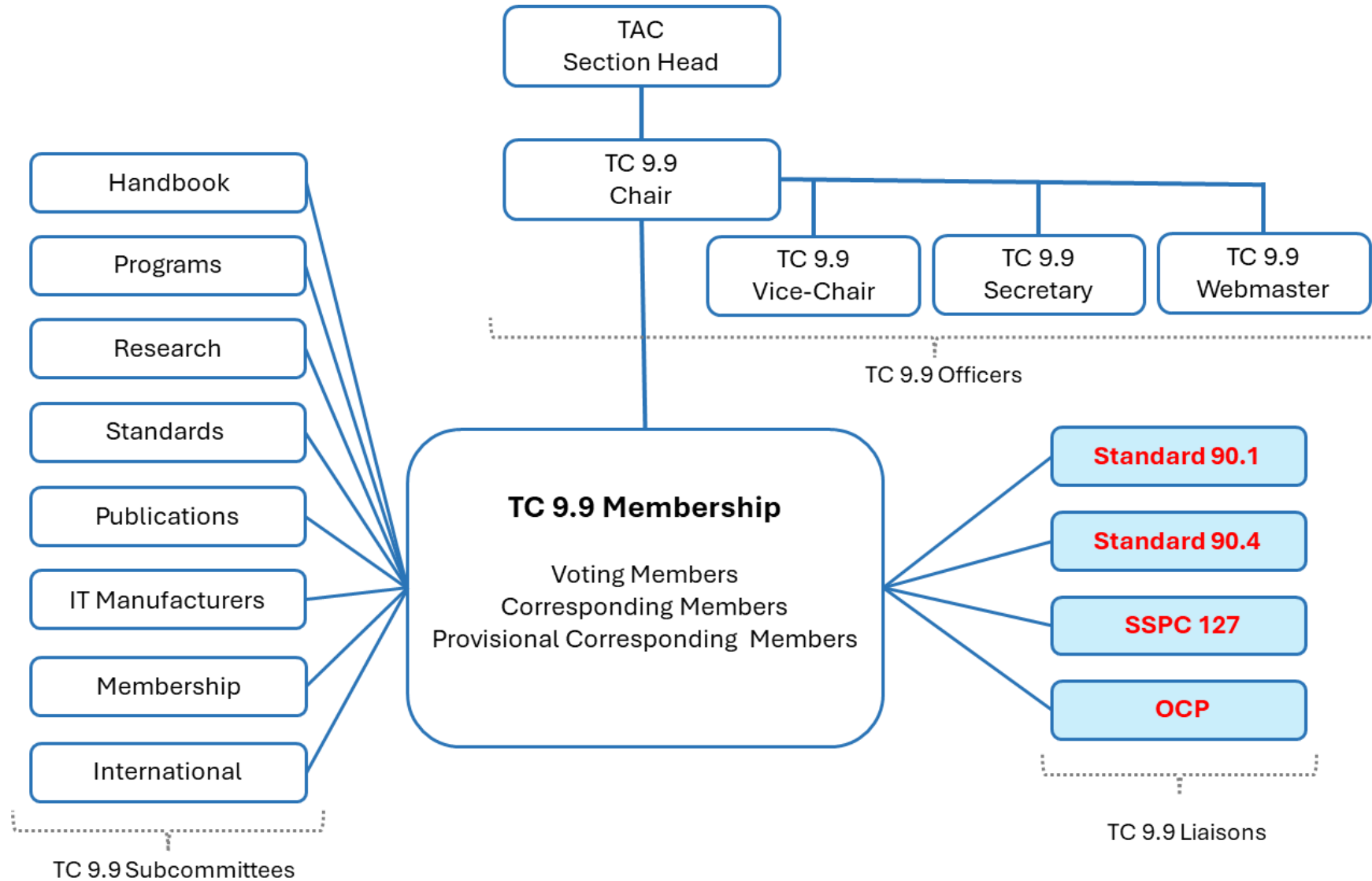

- 90.1 processed over 100 addenda that will be included in the 90.1-2025 Standard. Publication in early 2026.
- Review of Appendix M,N and O by TC9.9/SSPC 90.4 as these appendix reference net zero buildings.
- 90.1-2028-2031 Workplan has 2 major components-energy efficiency and net zero operational carbon. Looking like this will result in two 90.1 Standards.
- 90.1 will continue as a minimum standard focused on energy efficiency.
- 90.1E will be created to focus on ASHRAE Leadership goal of a net zero operational carbon by 2031.

90.4-2025 is PUBLISHED!



The 2025 edition of ASHRAE Standard 90.4 is a continuation of its mission to establish and refine criteria to enable the effective and optimal use of energy resources in the programming and design of data centers. The new edition strengthens data center sustainability by expanding the scope beyond energy efficiency to include greenhouse gas emissions, water use, and broader resource impacts. 90.4-2025 marks the publication of the fourth edition of the standard, affirming its position as an essential reference for the data center industry and broader Built Environment discipline. Learn more: <https://bit.ly/4rG5roN>



Data center design is evolving
and so is ASHRAE Standard 90.4.

ASHRAE 90.4 Addenda

Addendum D

- Air-Cooled Chiller / Liquid Cooling Baseline Models
- Adds a definition for Liquid Cooling
- Adds Total Annual Makeup Water/Sewer Cost of Mechanical Equipment to Annualized MLC
- MLC Value Refinements
- Adjusts MLC threshold from 300 kW to 1000 kW

2nd Public Review (ISC) Pending

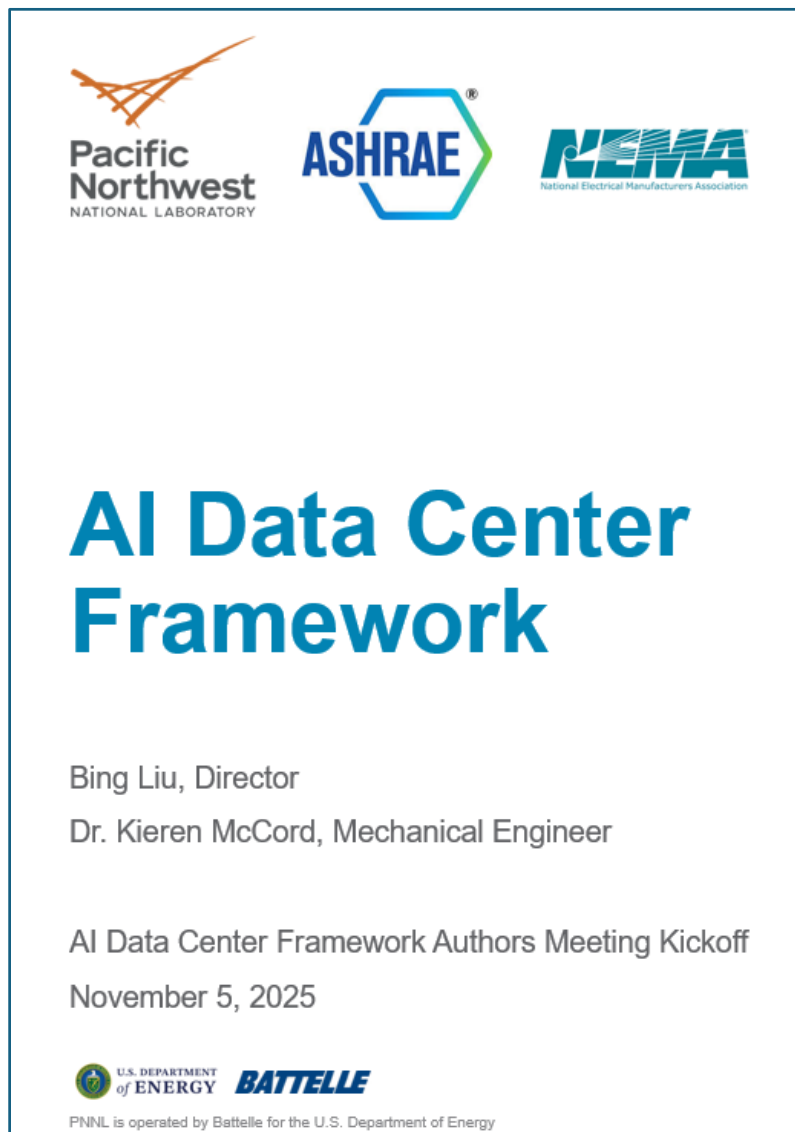

The image shows the cover of a document titled "AI Data Center Framework". At the top left, there are three logos: Pacific Northwest National Laboratory (PNL), ASHRAE, and NEMA (National Electrical Manufacturers Association). The title "AI Data Center Framework" is prominently displayed in large blue font. Below the title, the authors are listed: Bing Liu, Director, and Dr. Kieren McCord, Mechanical Engineer. Further down, it mentions "AI Data Center Framework Authors Meeting Kickoff" on "November 5, 2025". At the bottom left, there is a logo for the U.S. Department of Energy and Battelle, with a note that "PNNL is operated by Battelle for the U.S. Department of Energy".

Pacific Northwest
NATIONAL LABORATORY

ASHRAE

NEMA
National Electrical Manufacturers Association

AI Data Center Framework

Bing Liu, Director
Dr. Kieren McCord, Mechanical Engineer

AI Data Center Framework Authors Meeting Kickoff
November 5, 2025

U.S. DEPARTMENT
of ENERGY **BATTELLE**

PNNL is operated by Battelle for the U.S. Department of Energy

Center of Excellence for Building Decarbonization (CEBD)

AI Data Center Framework Document

PNNL
ASHRAE 90.4
NEMA

Targeting June 2026 Publication

Center of Excellence for Building Decarbonization (CEBD) AI Data Center Framework Document Proposed Framework Chapters

1 Introduction & Purpose

2 Planning & Siting

3 Integrated Design Principles

4 Energy & Thermal Efficiency

5 Grid-Interactive Design (Demand Flexibility)

6 Resilient Design

7 Commissioning & Performance Validation

8 Operations and Maintenance

9 Retrofit & Modernization Strategies

10 Tools, Standards, and Resources

ASHRAE Governmental Affairs

US Congressional Briefing December 2025

US Congressional Briefing

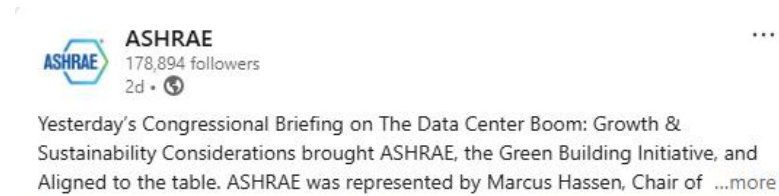

The Green Grid

TGG - ASHRAE Cooperation Agreement

TC 9.9
ASHRAE 90.4
ASHRAE 127



Local Chapter and University Outreach with YEA Leadership - Datacenters



ASHRAE 90.4 [Marketing Working Group]

Funding Request - APPROVED



ASHRAE Standard 90.4 SSPC 2028 Work Plan

Deliverable for ASHRAE 2026 Annual Conference

Why Collaborate?

- Generate wider knowledge base
 - Leverage unique strengths
 - Coordination of different voices in the value chain
 - Engagement from silicon to ambient
- Educate
 - Avoid duplication of work
- Collaborate
 - Shared/aligned roadmap
- Communicate
 - Published work; publicizing



OPEN
Compute Project®

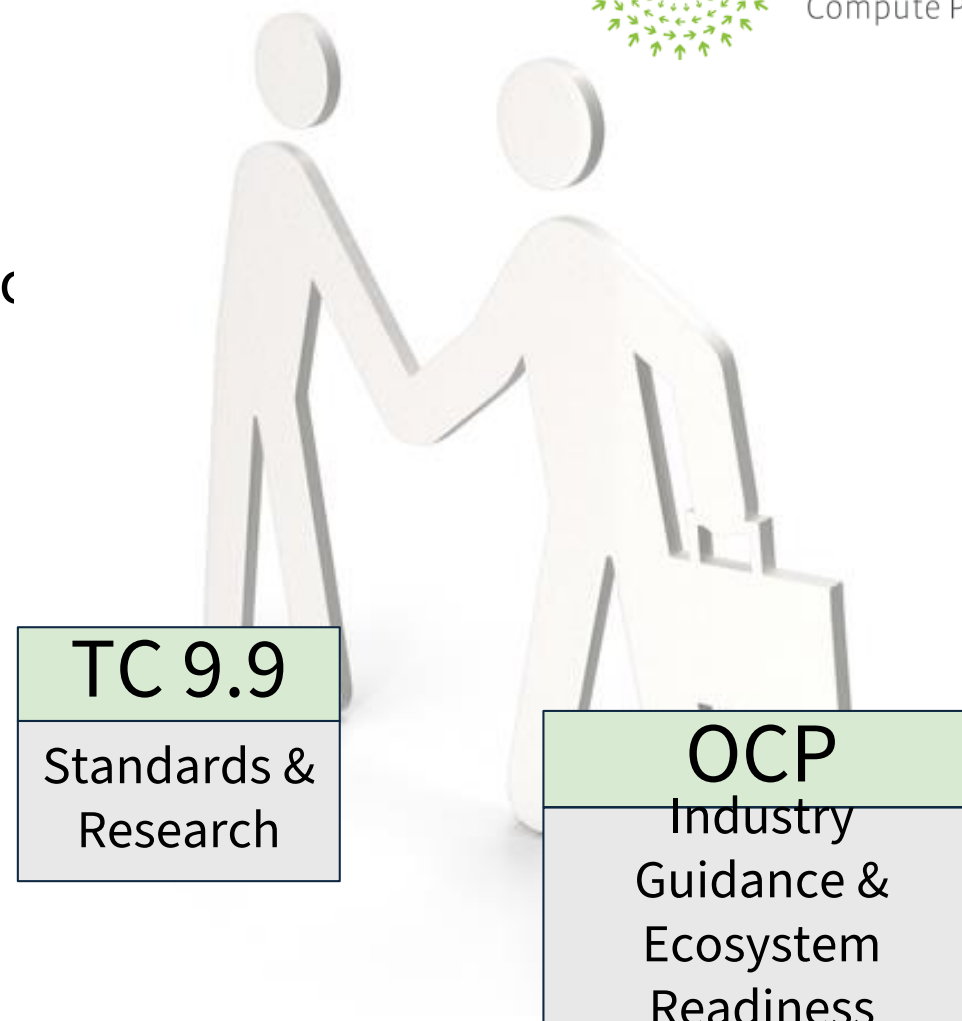

- Memorandum of Understanding (MoU) signed between ASHRAE and OCP.
- Quarterly Meetings between ASHRAE TC 9.9 Leadership and OCP Cooling Environments Project.
- Current Activities:
 - Fluid Velocity for erosion control
 - Upcoming RTAR
 - TCS Fluid Mixing
 - Upcoming RTAR
- Expand engagement with Data Center Facilities project within OCP.

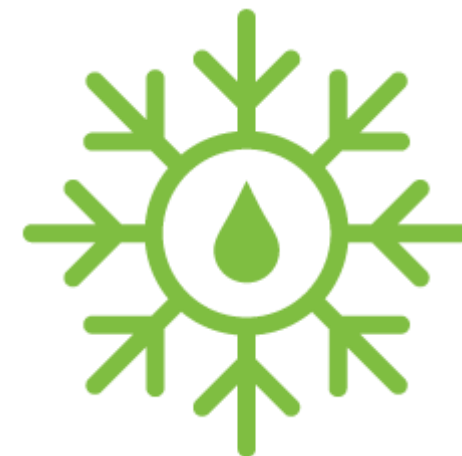

Title: Method of Testing for Rating Cooling Equipment Serving Data Center and Other Information Technology Equipment Spaces

Purpose: The purpose of the standard is to establish a uniform method of test requirements for rating cooling equipment that is applied in data center (DC) and other information technology facilities, spaces, and equipment..

Scope: This standard applies to classes of cooling equipment that are used to remove thermal loads in data center (DC) and other information technology facilities, spaces, and equipment.

SSPC Leadership:

SSPC 127 – Chair Dave McGlocklin, Vice Chair John Gross, Secretary Dave Meadows,

- Air Subcommittee – Chair Dave McGlocklin, Secretary Dave Meadows
- Liquid Subcommittee - Chair John Gross, Vice Chair Dr. Tim Shedd, Secretary Dustin Demetriou
- ASHRAE Staff - SPLS Liaison - William Healy, Staff Liaison – Thomas Loxley

2026 February Update & Plans:

Liquid Sub has released **Addendum b** covering the **L2L CDU MoT**. We received 56 public comments from the PPR & ISC Drafts, which we have worked through and compiled the updates into the released version. In parallel **L2A Addendum c** was worked on by the committee and we will be reviewing this proposed addendum during our Winter conference meeting.

Air Sub has been holding joint meetings with the AHRI 1360 committee on a monthly basis as we work on what will become **Addendum d**, which is a harmonized version of the standard. This effort removes redundant information from 127 that already exists in ASHRAE 37, as well as additions/removals of MoT/Rating content to the appropriate place in AHRI 1360.

2026 Plans

- Addendums for 2PH & Immersion liquid cooling topologies. Republishing most likely in 2027.

Meeting Tuesday Feb 3rd 8am-12pm (Caesars Palace, Octavius 12 (PS))



ANSI/ASHRAE Standard 127-2020
(Supersedes ANSI/ASHRAE Standard 127-2012)

Method of Testing for Rating Cooling Equipment Serving Data Center (DC) and Other Information Technology Equipment (ITE) Spaces

Approved by ASHRAE and the American National Standards Institute on November 30, 2020.

This Standard is under continuous maintenance by a Standing Standard Project Committee (SSPC) for which the Standards Committee has established a documented program for regular publication of addenda or revisions, including procedures for timely, documented, consensus action on requests for change to any part of the Standard. Instructions for how to submit a change can be found on the ASHRAE® website (<https://www.ashrae.org/continuous-maintenance>).

The latest edition of an ASHRAE Standard may be purchased from the ASHRAE website (www.ashrae.org) or from ASHRAE Customer Service, 180 Technology Parkway NW, Peachtree Corners, GA 30092. E-mail: orders@ashrae.org. Fax: 678-539-2129. Telephone: 404-636-8400 (worldwide), or toll free 1-800-527-4723 (for orders in US and Canada). For reprint permission, go to www.ashrae.org/permissions.

© 2020 ASHRAE ISSN 1041-2336



- **Reordered and expanded ToC to cover the new additions**
- **17 new definitions added to cover liquid cooling terminology**
 - ***Liquid to Liquid (Single Phase) Coolant Distribution Unit (CDU) for Information Technology Equipment:*** A heat exchange assembly or collection of components, “Assembly,” that separates the technology cooling system (TCS) coolant from the facility water system (FWS) or intermediate heat rejection system coolant (a liquid, which may or may not be water or a mixture of additives with water) where both coolants remain in the liquid phase and no heat is transferred through phase change. A heat rejection cooling capacity or capacities may be defined for this Assembly based on the heat rejected from the TCS coolant at a specified operating point or points using a specified coolant. The Assembly will have a measurable approach temperature for each operating point. A TCS coolant delivery flow rate may be defined for this Assembly based on the coolant flow that is generated by the Assembly at a given coincident pressure differential, fluid composition and temperature. The Assembly will have a measurable efficiency at the specified operating points.
- **New entry in Classification section for L2L CDU**
- **Calculations & Conversions**
 - Fluid Properties
 - Performance (Capacity, Power, Energy Efficiency)
 - Validation (Energy Balance & Voltage Balance)
 - Data Processing , Redundant Measurements, Rounding & Significant Digits

- **Test Requirements**
 - Test Instrumentation Accuracy, Resolution and relevant standard
 - Operating Condition Tolerances & Stability Criteria
- **Data to be Recorded**
 - Primary, Auxiliary, Optional
- **Test Procedures**
 - Procedures, Setup, Operation
 - Test Points
- **Reporting of Results**
- **Nomenclature**
- **References**

Table 9-1 Test Points – Liquid to Liquid CDU

<i>Test Point^b</i>	<i>FWS Temperatures</i>		<i>TCS Temperatures</i>	
	<i>EFT</i>	<i>LFT</i>	<i>EFT</i>	<i>EFT</i>
<i>Full Capacity (100%)</i>	<i>26C (78.8F)</i>	<i>30C (86F)</i>	<i>39.6C (103.3F)</i>	
<i>75% Capacity</i>	<i>26C (78.8F)</i>	<i>30C (86F)</i>	<i>37.2C (99.0F)</i>	
<i>50% Capacity</i>	<i>26C (78.8F)</i>	<i>30C (86F)</i>	<i>34.8C (94.6F)</i>	
<i>25% Capacity</i>	<i>26C (78.8F)</i>	<i>30C (86F)</i>	<i>32.4C (90.3F)</i>	
<i>Minimum Capacity^a</i>	<i>26C (78.8F)</i>	<i>30C (86F)</i>	<i>N/A</i>	

a. Minimum capacity test point to be performed with automatic flow controls active at the minimum flow rate at which the CDU automatically maintains TCS side flow within the required flow test tolerances- listed in Table 7-3.

b. Tests for 100%, 75%, 50%, and 25% Capacity are performed at Constant TCS Flow Rate equal to the flow rate used for the 100% Capacity Point.

- **Informative Appendix**
 - Application Testing
- **Normative Appendix**
 - Measurement Points

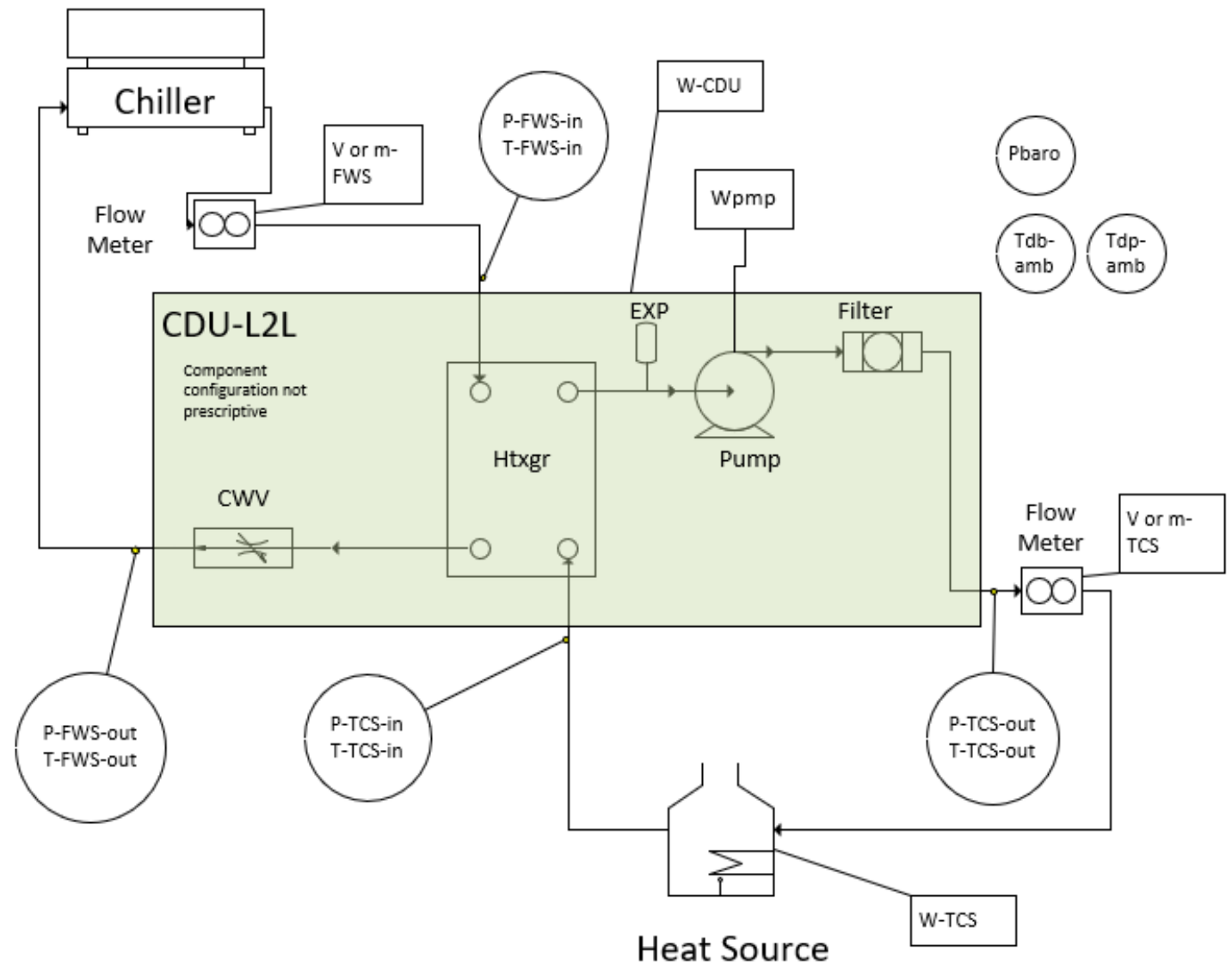

Handbook Subcommittee

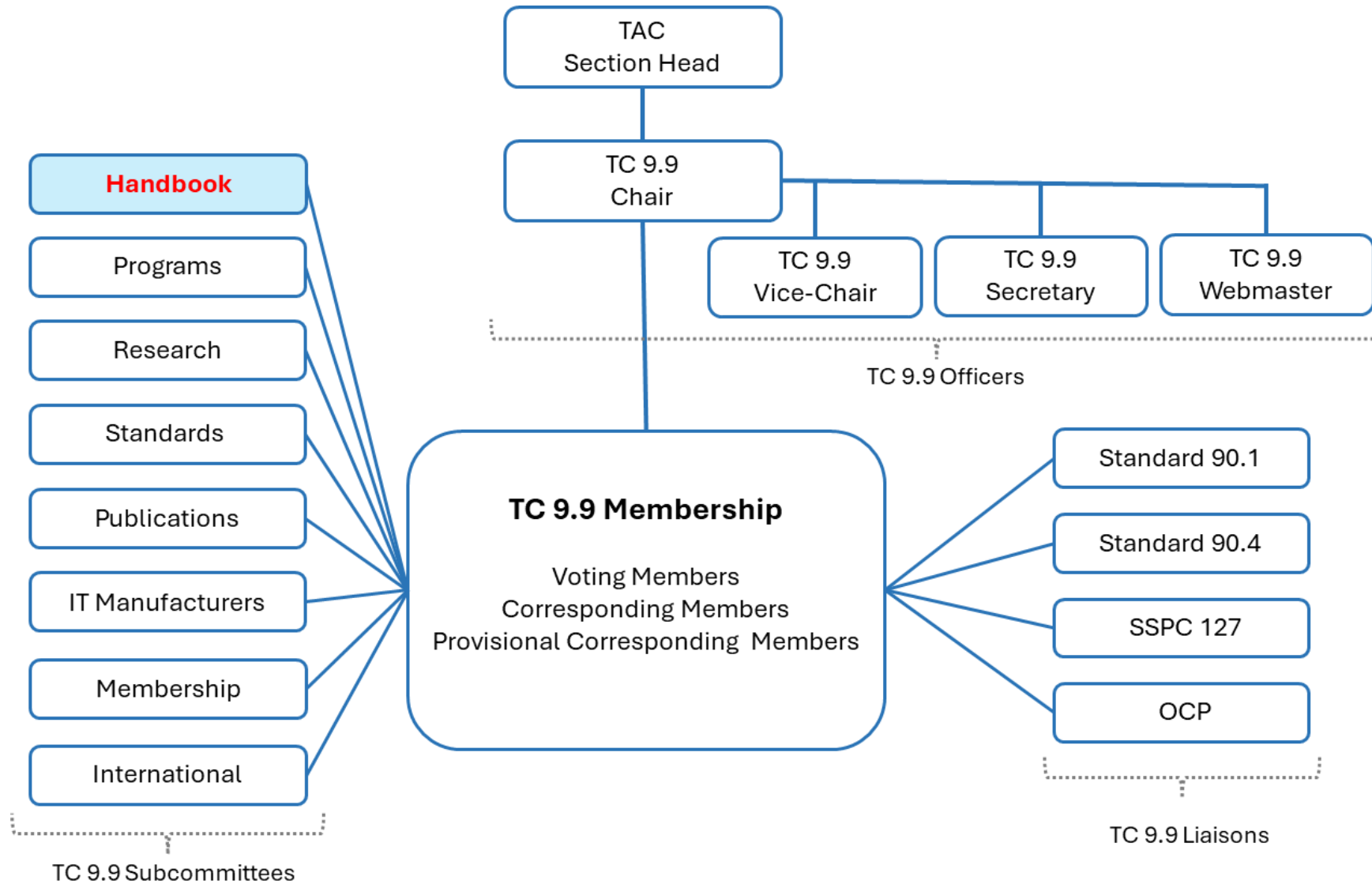

- Background
- Purpose of “Applications”, Chapter 20
- Current Status
- Today’s Priorities
- Next Steps
- Questions

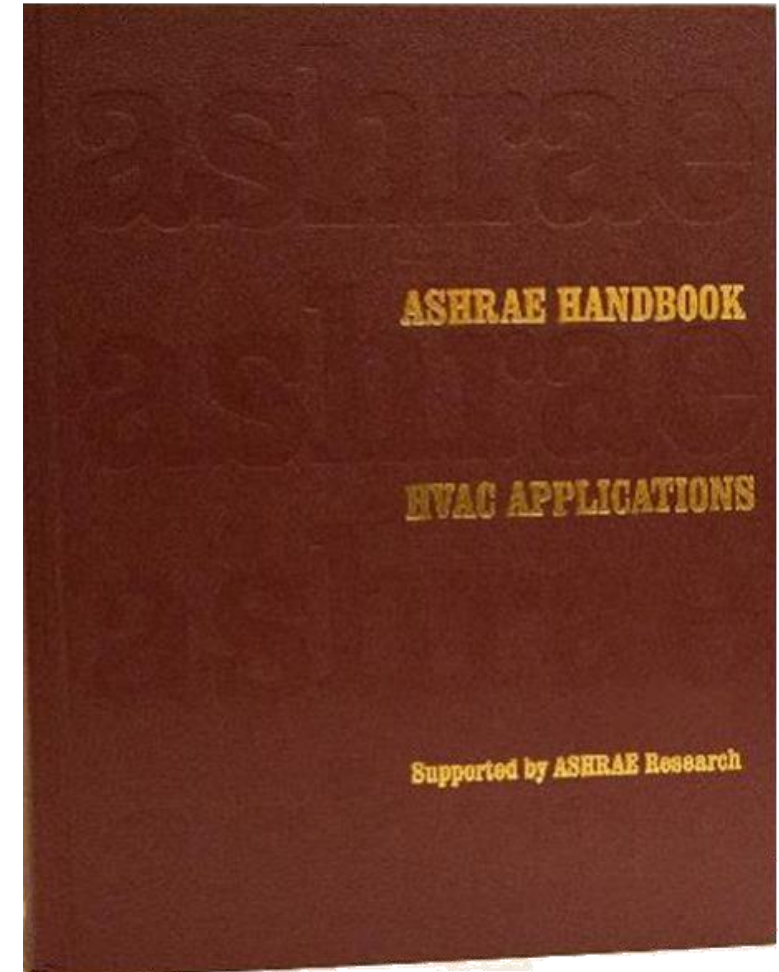

- “Handbook” is ASHRAE’s Most Important Publication
 - Tutorial for New Engineers
 - Reference for Experienced Engineers
 - An Alert to “What You Don’t Know”
 - Encourages Retaining Subject Matter Experts
 - “Best Practices” Information
 - Legal Reference

- “It’s Also ASHRAE’s Most Important Product
 - Worldwide Face of ASHRAE
 - A Unique Product
 - Prime ASHRAE Member Benefit
 - Handbook Online, PDF or Print
 - Basis for ASHRAE Codes and Standards
 - **The Public “Face” or Our TC !!**
 - **The Quality of our Chapter Reflects the Quality of Our TC**

- ASHRAE's Handbooks - Four Publications
 - ✓ *Fundamentals*
 - ✓ *Refrigeration*
 - ✓ ***Applications***
 - ✓ *HVAC Systems and Equipment*
- Published on Four-year Cycle
- TC9.9's Responsibility: Chapter 20 of "Applications"
 - *"Data Centers and Communications Facilities"*
- All Revisions by Volunteers through TC9.9

Chapter 20 Has 120 Topics:

- 29 Initial Reviewers
 - 4 New Topics Suggested for Addition
 - Heat Pipe Technology
 - Above Hot Aisle Air Delivery
 - Controls
 - Digital Twin

24 Revisors

THANK YOU ALL !!!

- Jonathan Bastien
- Chris Campbell
- Brad Chen
- Uschas Chowdhury
- Carlos Lisboa
- Tom Davidson
- Dustin Demetriou
- Ben Dolcich
- Dan Donahoe
- Ed Gutowski
- John Groenewold
- Ali Heydari
- Alex Hubbard
- Roger Huggins
- Matthew Kaufeler
- Steve Kujak
- Dave McGlocklin
- Chris Muller
- John Murgida
- Ben Petschke
- Joe Prisco
- Terry Rodgers
- Russ Tipton
- Eric Yang

We are now at the END of our revision cycle for the Applications Handbook!

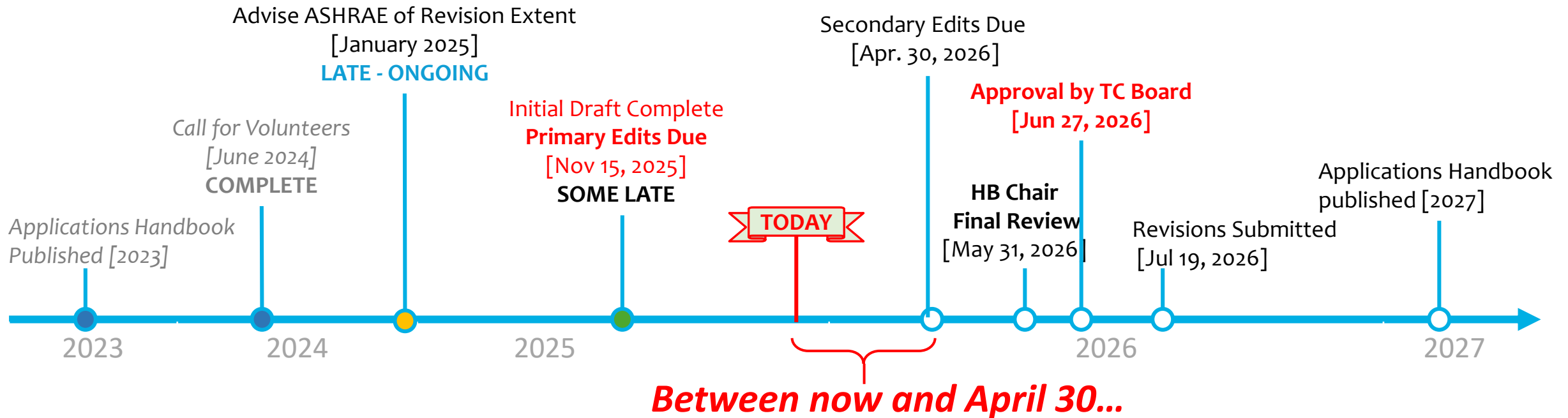

1. <TODAY> Get volunteers for unassigned topics Work Session!!
2. Secondary Section Reviews Complete **(One Assignment Remaining)**
3. References and Bibliography Review & Revisions **(Need Volunteers)**

Get Reviewers for Topics Not Covered (Winter Meeting Work Session)

**NEED TO KNOW NOW
TO ENSURE YOU HAVE
“AUTHORING PORTAL” ACCESS**

Unassigned Topics		
ID	Section	Topic
7	2.2 Datacom Equipment Racks	With Fig. 2 & # (ID 111 & 112)
37	3.1 General Considerations	Lighting
52	3.2 Air Cooling	Row-Based Cooling
65	3.3 Liquid Cooling	Piping Distribution System (W/ Fig. 16 – ID 125))
97	4. Resources	ANSI/TIA Std. 942-B
98	4. Resources	ANSI/BICSI Std. 002
99	4. Resources	ANSI/ASHRAE Std. 202
100	4. Resources	ASHRAE Guideline 0
101	4. Resources	BICSI 009
102	4. Resources	The Green Grid White Paper #79
103	4. Resources	The Green Grid White Paper #68
105	4. Resource	ISO/IEC 22237 Series
106	4. Resources	European Commission - The European Code of Conduct for Energy Efficiency in DCs
107	References	-
108	Bibliography	-

Please advise Bob McFarlane and Jonell Watson
rmcfarlane@smwllc.com | Jonell@hudson-trading.com

- Complete All Initial Edits
- **Assign Secondary Reviewers**
 - Section 1 Jeshwanth Kundem
 - **Section 2** ???
 - Sections 3.1 & 3.2 Rohit Dhumane
 - **Sections 3.3 & 3.4** ???
 - Section 4 Santosh Shekar Mudunur

ANOTHER IMPORTANT CONCERN

**Are We In Conflict With Any Other
Handbook Chapter or Standard?**

**We Started to Look at “Overlaps”, but
the Ball**

Dropped

TC 9.9 Must Consider & Research

QUESTIONS?



Please advise Bob McFarlane or Jonell Watson
rmcfarlane@smwllc.com | Jonell.watson@hudson-trading.com

Programs Subcommittee

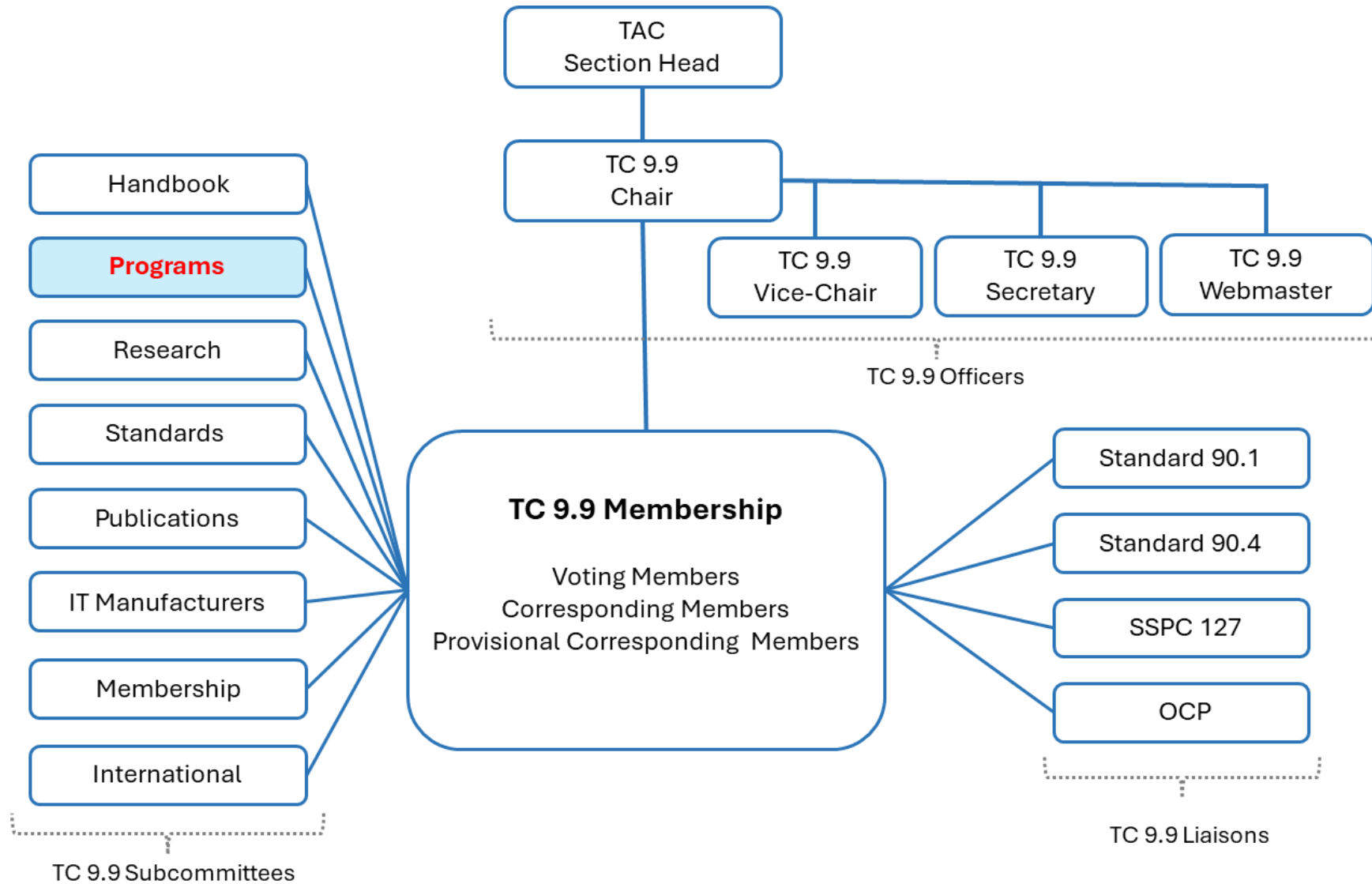

- Paper Session 7 (Sponsored by TC 9.9)
 - Overcoming Challenges in Coolant Distribution Unit (CDU) Testing and Troubleshooting: Key Insights and Lessons Learned - Author: Pardeep Shahi
 - Time: Sunday 2/1/26 1:30 PM – 3:00 PM PST
- Paper Session 24
 - Efficient, Low-Carbon Cooling Strategies for Buildings and AI-Intensive Data Centers
 - Optimizing Data Center Cooling across Climates: Modeling PUE and WUE
 - Optimizing Data Center Energy Efficiency By Cooling Fluid Type and Supply Temperature in Immersion Cooling Systems
 - Time: Tuesday 2/3/26 3:15 PM – 4:45 PM PST
- Seminar 46
 - Time: Tuesday 2/3/26 3:15 PM – 4:45 PM PST
- Paper Session 26
 - Modeling Mechanical Cooling Equipment for Data Centers across U.S. Climate Zones to Optimize Power and Water Usage -Author: Pooya Navid
 - Time: Wednesday 2/4/26 8:00 AM – 8:20 AM PST
 - The Technical Qualification of a High-Reliability, Enterprise-Grade Technology Cooling System (TCS) Loop for Information Technology Equipment -Author: Dustin Demetriou
 - Time: Wednesday 2/4/26 9:20 AM – 9:40 AM PST

- Seminar 3
 - Airflow Modeling for Flexible and Resilient Critical Facilities Design -Chair - Wangda Zuo (TC4.10, TC9.9)
 - Time: Sunday 2/1/26 8-9 AM PST,
- Seminar 26
 - The Liquid Revolution: Best Practices in Cooling for Tomorrow's Data Centers -Chair: Sarah Hilden (TC6.1, TC9.9)
 - Time: Sunday 2/1/26 11:00 AM – 12:30 PM PST
- Seminar 39
 - Decarbonization for Different Applications Such as Waste Heat Harvesting and Data Center –Chair Aida Rezaei (TC2.5, 8.2)
 - Time: Tuesday 2/3/26 9:45 AM – 10:45 AM PST
- Seminar 44
 - Surrogate Models for Fault Detection in Wshps and Heat Island Effects in Data Center Chiller Plants –Chair Rohit Dhumane (TC1.13)
 - Time: Tuesday 2/3/26 12:20 PM – 12:40 AM PST
- Seminar 58
 - Dry Coolers for Data Center Applications –Author: Christian Bach (TC8.3)
 - Time: Wednesday 2/4/26 11:00 AM – 12:30 PM PST
- Other meeting related to AI data center:
 - AI Data Center Framework Authors Meeting
 - Time: Sunday 2/1/26 1:00pm – 4:00pm PST

- Want to develop TC 9.9 conference content
- Target 2027 Winter Conference - Chicago
- Plan to organize a mini track (three or more sessions) focused on data center applications at Winter conference 2027.
- Conference Paper Abstracts and Paper Session Requests Due
 - **Wednesday, May 28, 2026** (Estimated)
- Please notify Eric Yang (ericyangcem@gmail.com) once you received the acceptance from ASHRAE
- If we have enough papers to organize and put as a mini track.
- Will contact ASHRAE to follow up the co-sponsorship at Las Vegas conference

- Panel Track 1: Urgent TC 9.9 topics
 - Datacom Online Encyclopedia
 - Major Encyclopedia Updates
 - Technical Alerts
- Panel Track 2: FWS/TCS
 - CDU testing (SSPC 127)
 - Flow Velocity
 - Fluid quality
 - Filtration
 - Monitoring & Maintenance
- Panel Track 3: Commissioning
 - FWS/TCS
 - Best Practices
 - Pre-ITE
 - Post-ITE
- Panel Track 4: Energy Efficiency
 - Power Trends
 - Best Practices
 - Heat Recovery / Reuse
- Panel Track 5: Emerging Technologies
 - ARPA-E COOLERCHIPS as example
 - Quantum compute

Overview of Conference Tracks

- Fundamentals and Applications
- HVAC&R Systems and Equipment
- Research Summit
- Workforce Development
- Ground Source Heat Pump
- Hot Climate, Building Design, Operation and Resilience
- AI in Building design and Construction
- Building decarbonization

- **Fundamentals and Applications Track**
 - Technical alert seminar (recent published)
 - IT load Power trend and cooling requirement
- **HVAC&R Systems and Equipment Track**
 - Modular Electrical Room Design in Data Centers (seeking speakers)
 - TCS Loop CX best practice
 - CDU testing using SSPC 127 - Dave McGlocklin
 - TCS/FWS chilled water loop Flow Velocity or Fluid quality Monitoring & Maintenance
 - TCS Commissioning (Pre-ITE and Post-ITE)
 - Debate (90.1 scope requirement on TCS Loop: whether this should be exempted – John Gross

- **Research Summit**

- OCP & ASHRAE TC 9.9 Collaboration - Status, Workstreams, & Path Forward
- ARPA-E Cool Chip program update

- **Workforce Development**

- Data center engineering workforce development
- Datacom Online Encyclopedia update
- Ai Factory workforce training

- **Building decarbonization**

- Data Center decarbonization best practice

Important Dates...

- **Monday, February 25, 2026**
 - Debate, Panel, Seminar, Forum, Workshop, and Debate Proposals Due
- **Monday, February 25, 2026**
 - Conference Papers and Extended Abstracts Due

Next Steps...

- Contact Eric Yang at ericyangcem@gmail.com
- If you need
 - Co-sponsorship from other TCs
 - ASHRAE speaker submission template
 - To understand the process of submitting a session

BREAK – 20 Minutes



ASHRAE TC 9.9 Attendance Record

ASHRAE Technical Committee 9.9 - Mission Critical Facilities, Data Centers, Technology Spaces and Electronic Equipment

Meeting Attendance is tracked via a Google form. Please complete the attendance form for each meeting...

Direct Link:

<https://forms.gle/CmPCtGqXyqZJntTQ8>

2026 Winter Attendance Form

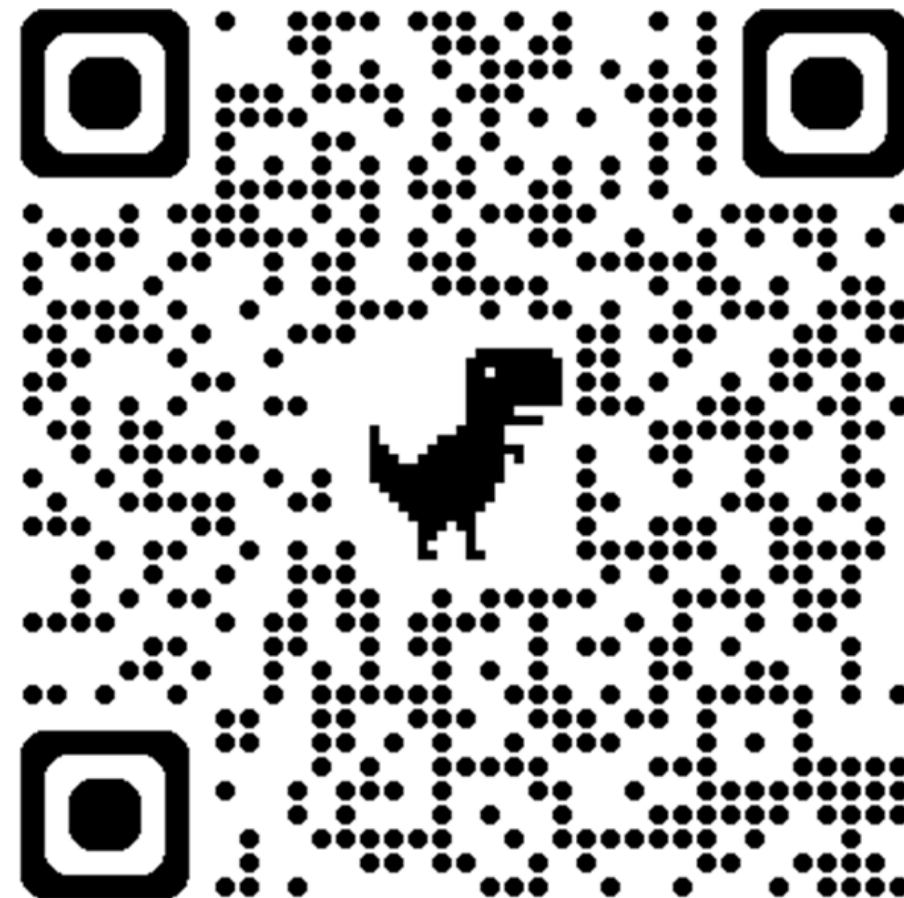

<https://forms.gle/3oAAsj5ZVHqT9f6M6>

Research Subcommittee

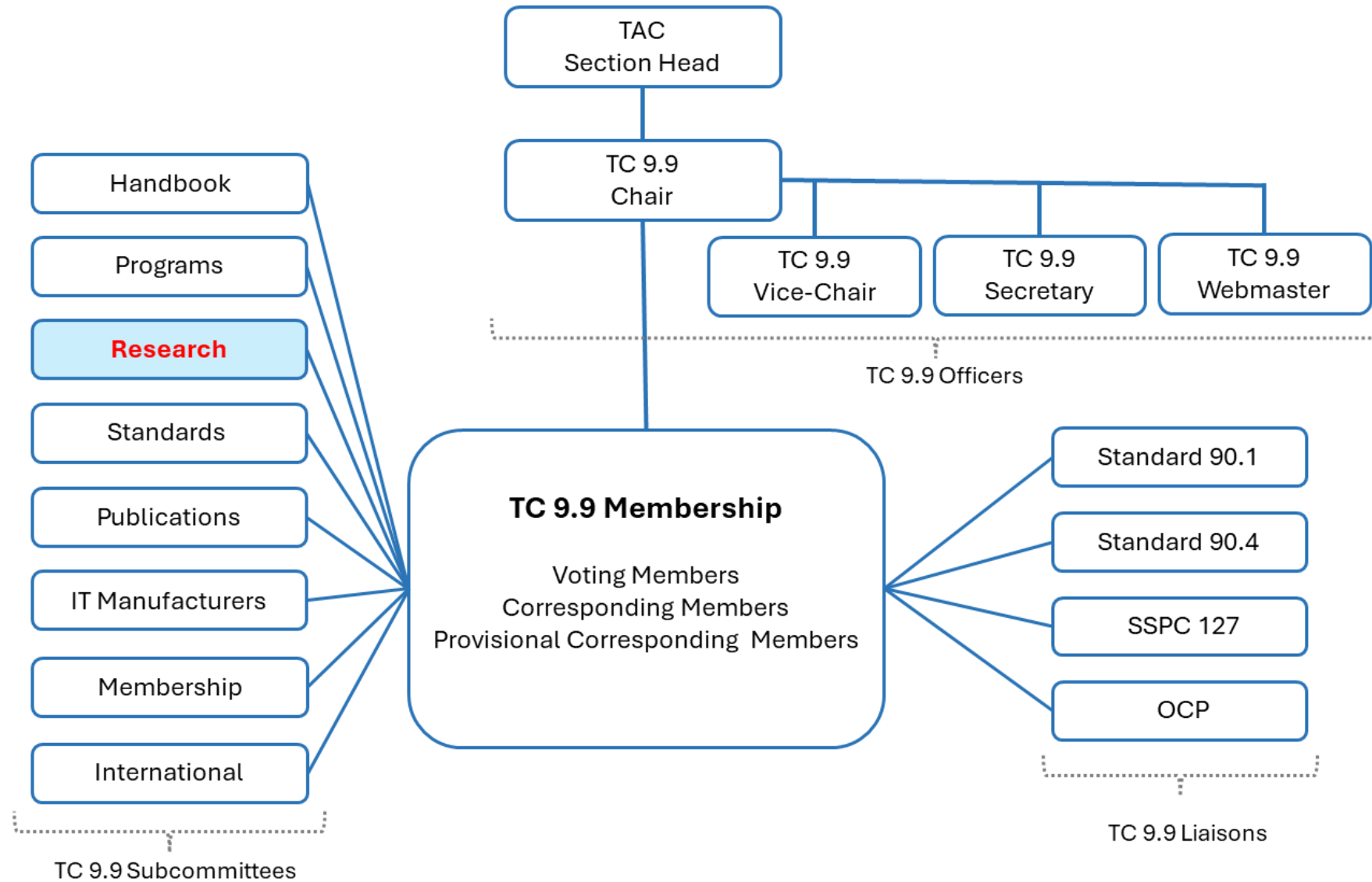

RP-1890 Update

Minimum flow velocities for purging air and debris from hydronic piping systems

George Land, PurgeRite

RP-1913 Update

**Study of the Corrosion Impact on Information
Technology Equipment in Data Centers Located in
Coastal Regions with High Sea Salt Concentration**

PI: Dr. Lihong Lao, CO-PI: Dr. Jianshun “Jensen” Zhang

TRP-1913 - *Study of the Corrosion Impact on Information Technology Equipment in Data Centers Located in Coastal Regions with High Sea Salt Concentration* (Chris Muller)

Research was awarded in Summer 2025
Project underway.

TRP-1972 - *Data Center Direct-to-Chip Liquid Cooling Resiliency – Failure Modes and IT Throttling Impacts* (Tom Davidson)

Bids have been received and being reviewed by the PES. Expect vote on the selected bidder during executive session on Monday.

WS-1956 - *Compact CFD Modeling Guidance for Thin Flow Resistances*
(Jim Van Gilder, et al.)

TC4.10 is the cognizant TC, TC9.9 is a Co-Sponsor
Difficulty getting buy-off from RAC. May drop.

RTAR ##### – *Effective Dispersal Volume Dynamic Reaching Height for Flammable Refrigerant Releases* (Rick Pavlak)

Submitted to RAC for review in December 2025

RTAR ##### – *Guidelines for Data Center External Dispersion Modeling* (Brad Cochran)

Uploaded to RTAR Portal

Co-Sponsored by TC4.3 and TC4.10 (Voting on During Main Meetings)

Need vote from TC9.9

RTAR in Development – *Flow Velocity Limits for Erosion Control* (Mark Steinke)

Proposed RTAR - *Digital twin for data center environments for liquid cooling and how that might be able to be developed* (Ali Heydari)

Research Project Development Flow Chart

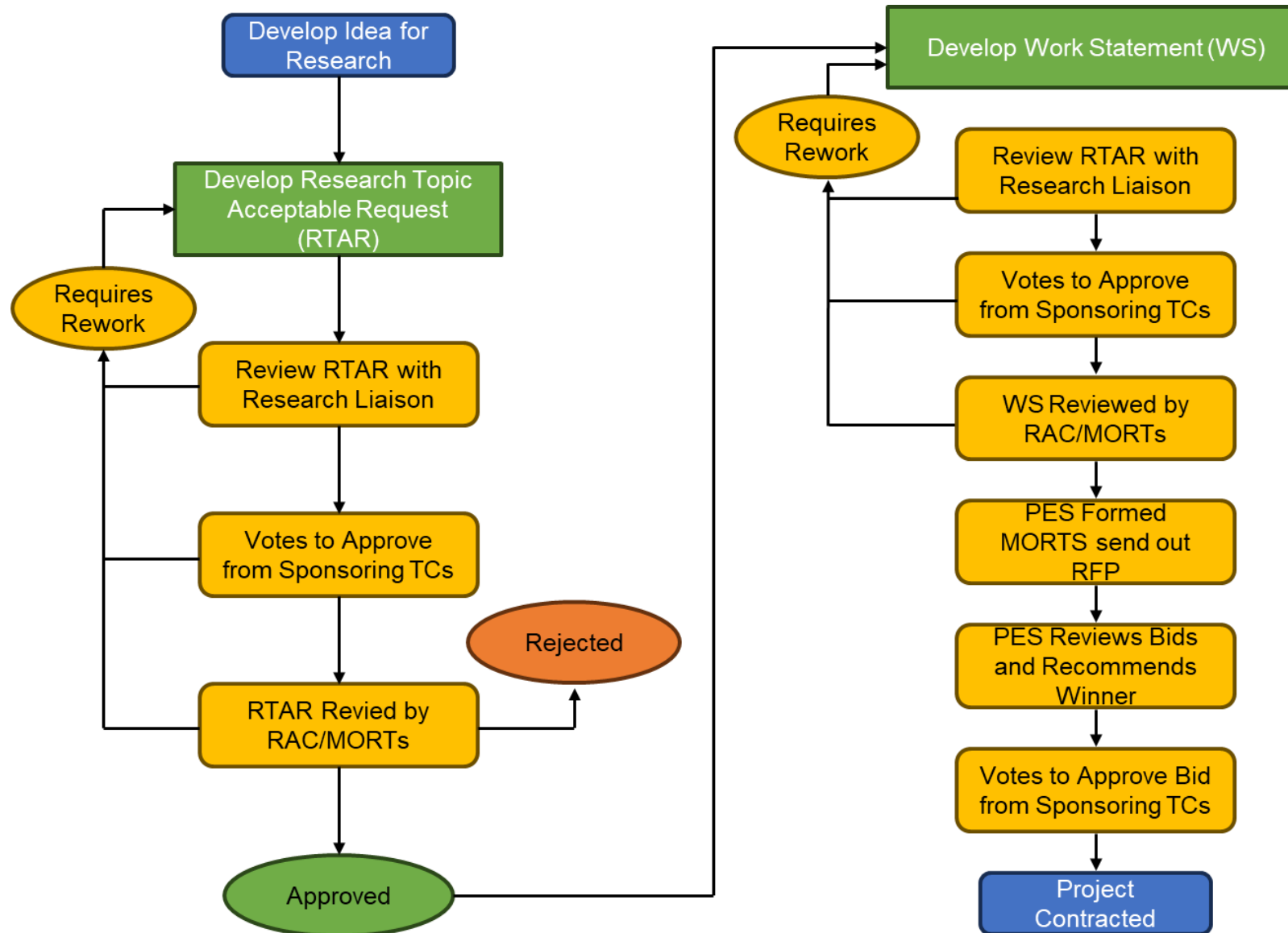

Research Project Development Flow Chart

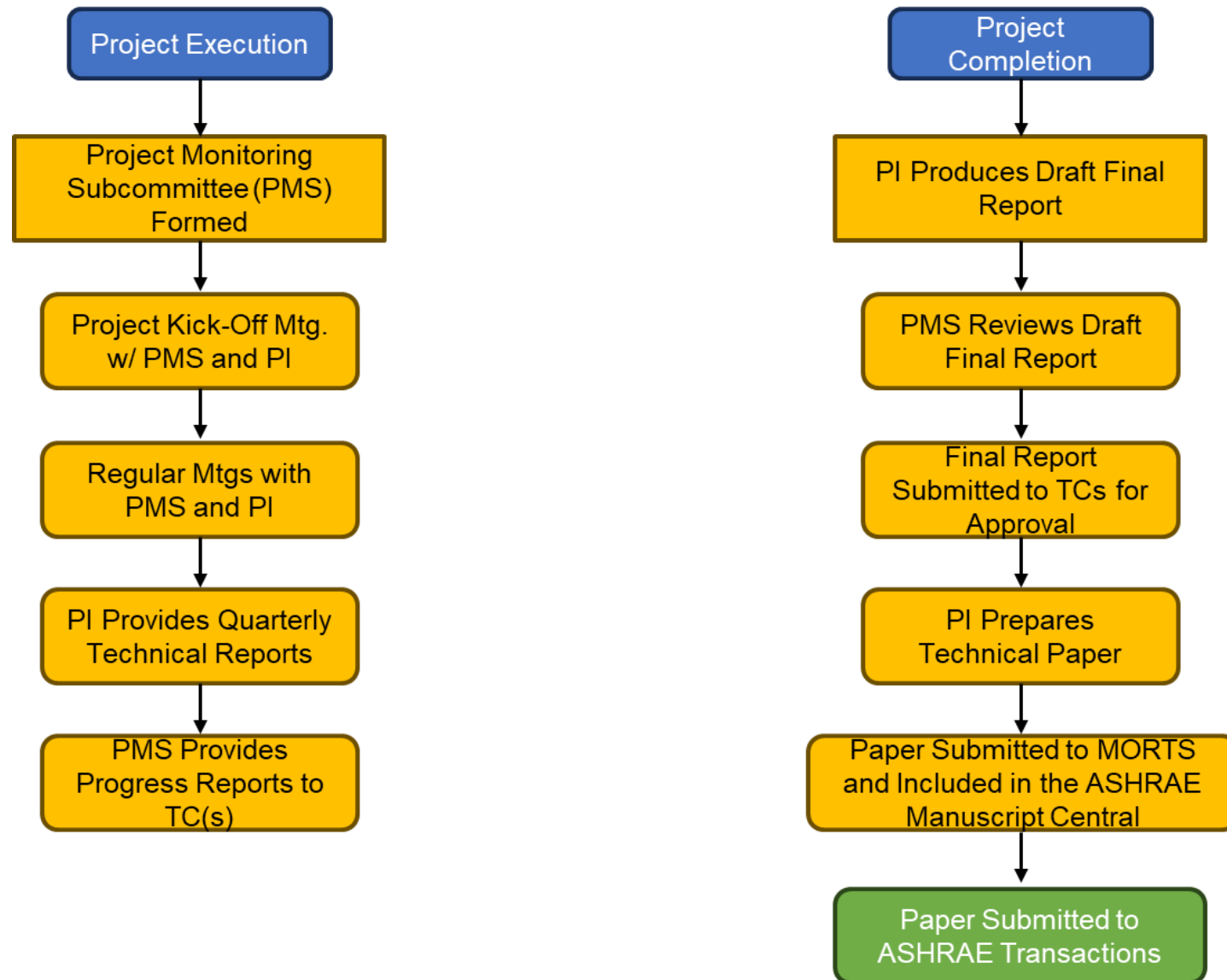

International Subcommittee

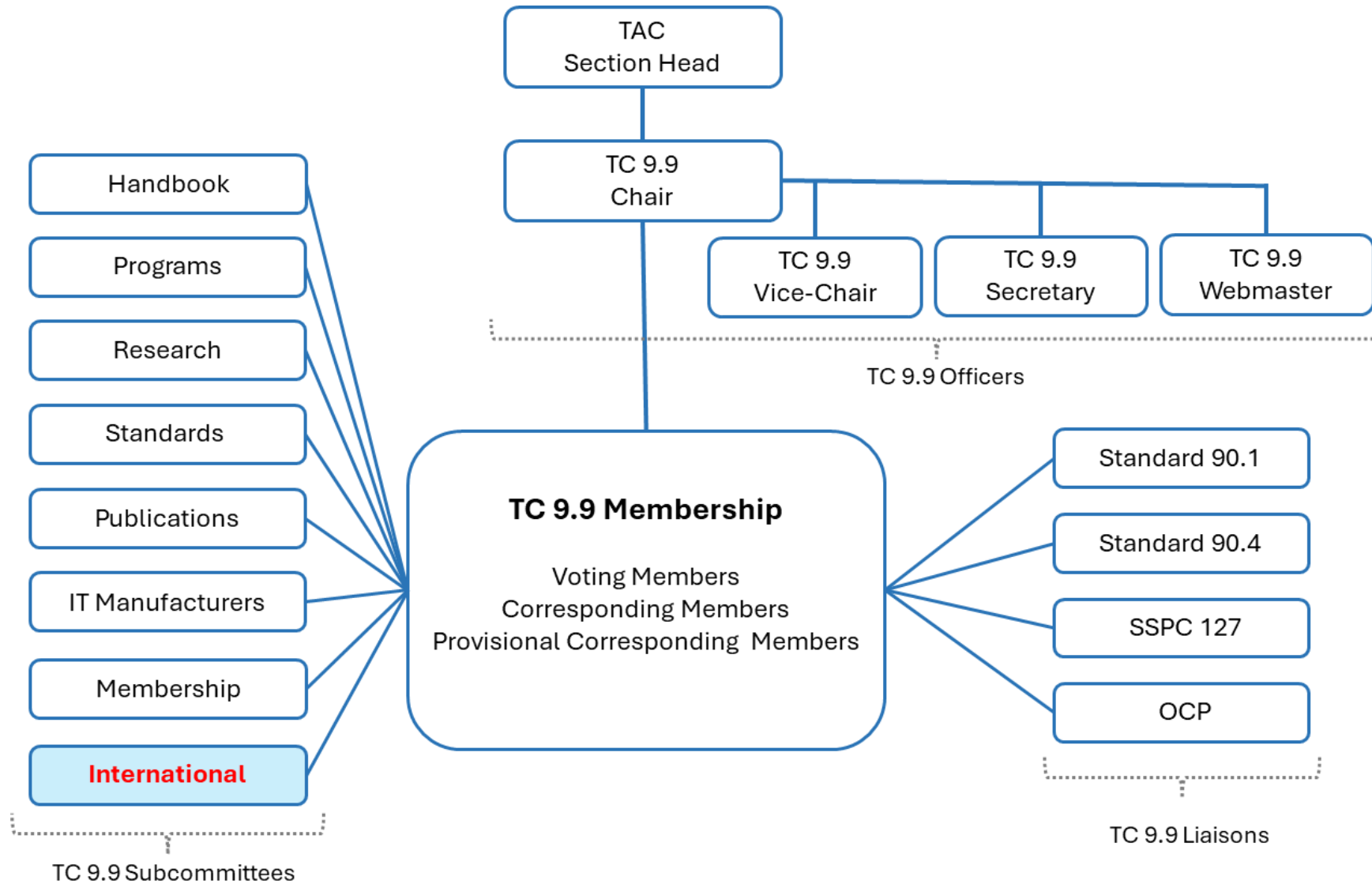

- ASHRAE Technical Committee 9.9:  **LinkedIn**
- **Background:** supported by ASHRAE and with agreement of the Voting Members, the TC9.9 LinkedIn site launched back in June 2018.
- **Purpose:** to raise the awareness and relevance of the work of ASHRAE TC9.9 using a digital platform, providing greater accessibility for members and non-members globally and conduit to the web-site and bookstore to better access information.
- **Scope:** updates spanning meetings, publications, standards and research.
- **Relevance:** the data centre industry is arguably at a point of inflection not seen since the advent of cloud computing. There is a thirst for guidance and standards relating to the thermal environment.
- **Next steps:** content drives site activity and the many workstreams in flight today provide the opportunity for more frequent updates. These opportunities are not always obvious, and pertinent updates should always be put forward by the group.
- **Statistics:** see over.

Followers:

ASHRAE TC 9.9
2,890 followers

Mission Critical Facilities, Data Centers, Technology Spaces and Electronic Equipment

Industrial Machinery Manufacturing · Atlanta, Georgia · 3K followers · 51-200 employees

Brad & 5 other connections work here

Message Following

Home About **Posts** Jobs People Insights

All Images Videos Articles Documents

Sort by: Top

ASHRAE TC 9.9
2,890 followers
2w · Edited ·

The ASHRAE Winter Conference and AHR Expo takes place from January 31 to February 4. The ASHRAE TC9.9 meeting schedule has been released, covering programs, research, handbooks, ...more

ASHRAE TC 9.9
Mission Critical Facilities, Data Centers, Technology Spaces and Electronic Equipment

ASHRAE Winter Conference 2026
Las Vegas, NV

Conference Meeting Schedule
Hybrid In-Person / Virtual

You and 67 others 7 reposts

Geographic Snapshot: Purpose achieved – global audience

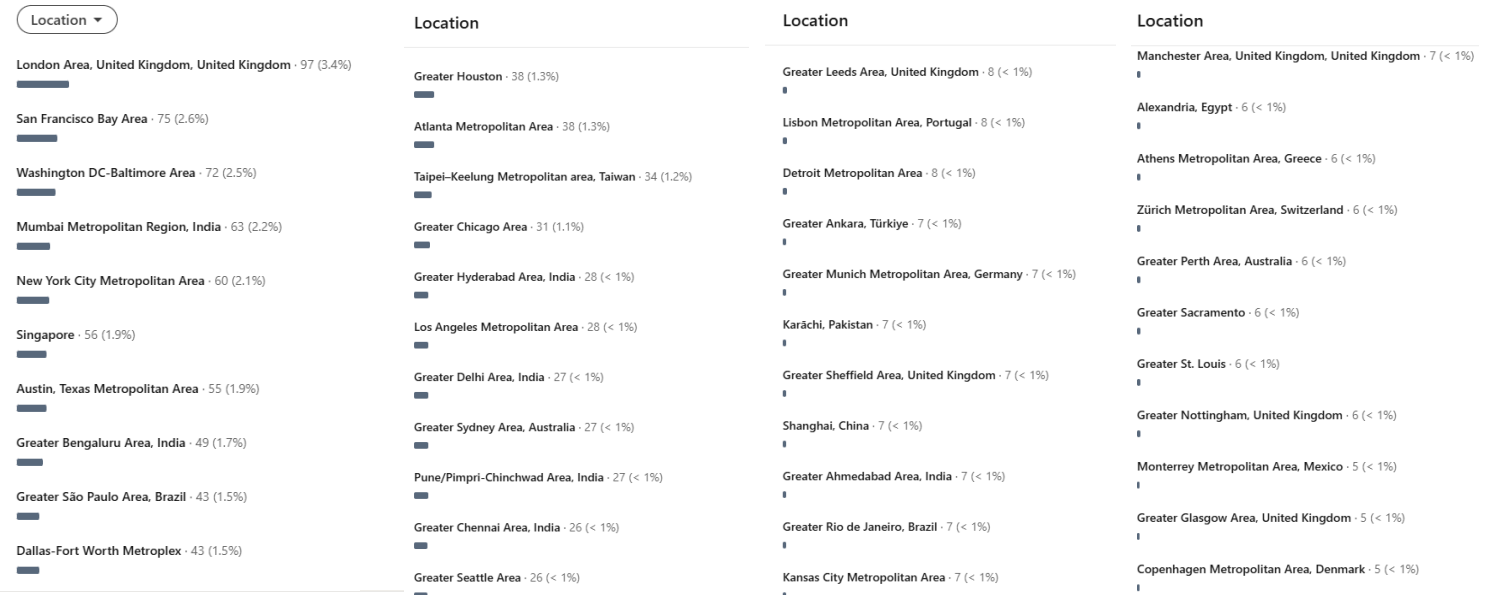

Follower highlights

2,890 Total followers

1,385 New followers in the last 365 days

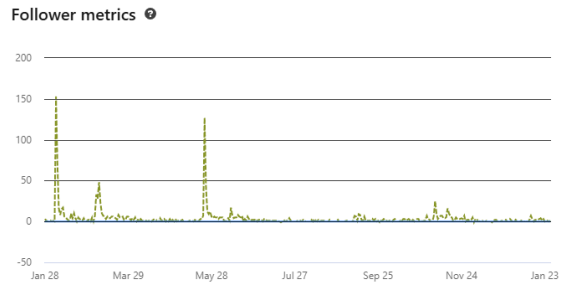

- Standards & Guidelines:
 - European Commission: Review of the Ecodesign Regulation on servers and data storage products 2019/424 (and potential energy label for servers)
 - European Commission have published the 2025 Best Practice Guidelines for the EU Code of Conduct on Data Centre Energy Efficiency (2025)
- Groups:
 - ASHRAE UK Chapter: Data Centre Special Interest Group: <https://www.ashrae.uk/about/> (2025)
 - CIBSE Data Centre Interest Group: <https://www.cibse.org/get-involved/special-interest-groups/data-centres-group/> (2025)
- Next steps:
 - Expand international updates to include:
 - MENA
 - APAC

Publications Subcommittee

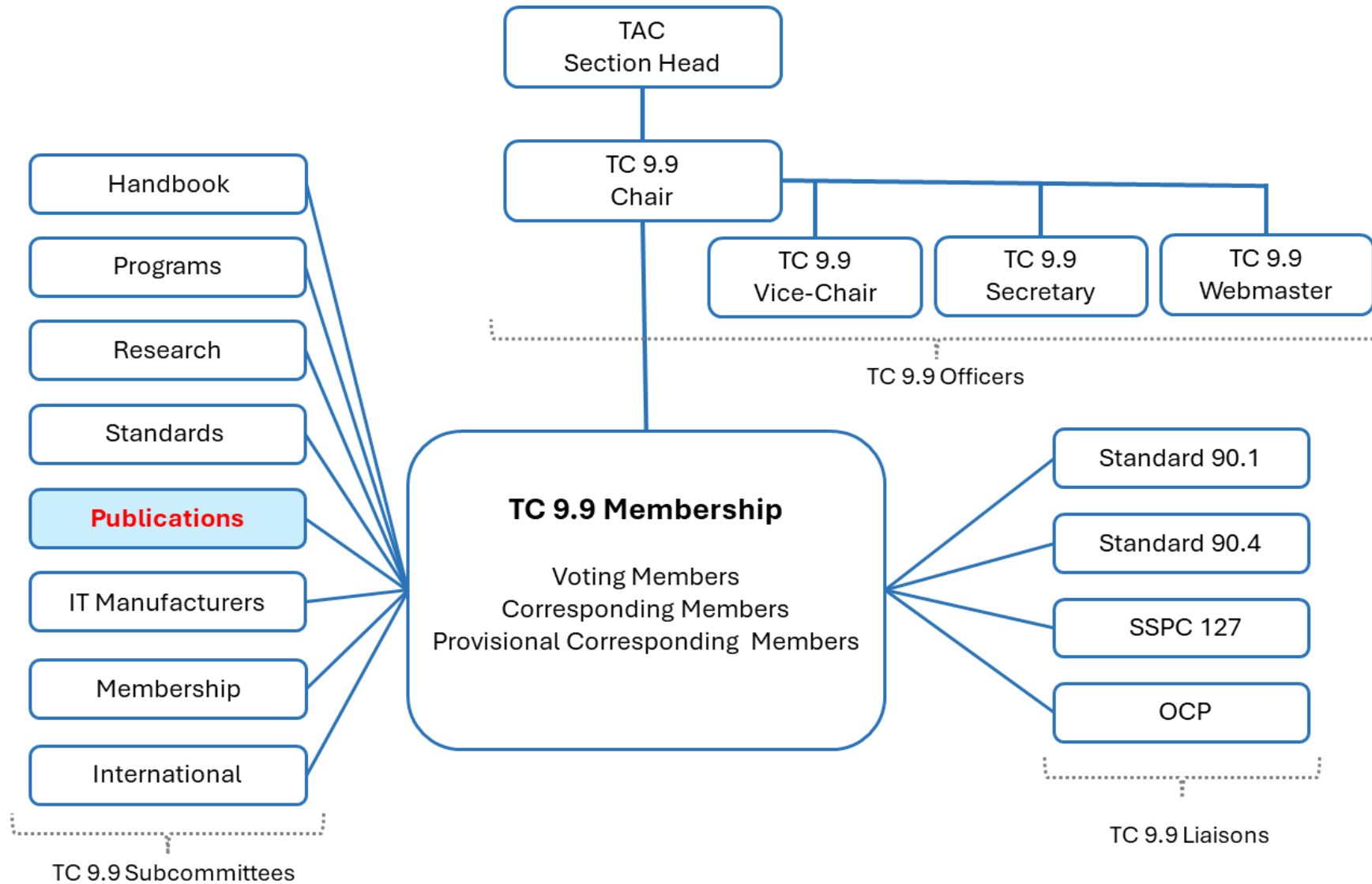



The [ASHRAE TC 9.9 Datacom Encyclopedia](https://datacom.ashrae.org) evolved in 2024 from the longstanding ASHRAE Datacom Series, a series of print books that provides information on data center-related subjects.

The Datacom Encyclopedia offers **updated, previously unpublished content** formerly covered by the Datacom Series books *Thermal Guidelines for Data Processing Environments*, *Design Considerations for Datacom Equipment Centers*, and *Liquid Cooling Guidelines for Datacom Equipment Centers*, as well as **PDFs of every edition of the 14 books in the ASHRAE Datacom Series** for historical reference. Over time, the pertinent information from all the books will transition to be housed in this online encyclopedia.

Subscribe today to access the ASHRAE TC 9.9 Datacom Encyclopedia. Access is granted via payment of an annual fee (\$33 list price per year / \$24 Member price per year).

To enable and disable access to the encyclopedia, visit <https://datacom.ashrae.org/> and click Manage Subscription in the top blue bar. Users can review ASHRAE's privacy policy at www.ashrae.org/privacy-policy.

Datacom Encyclopedia

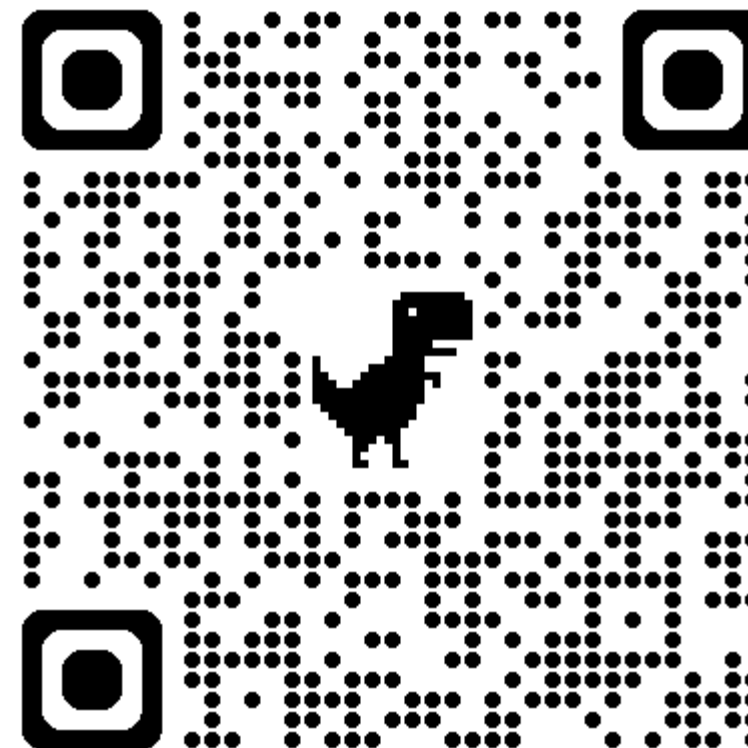

<https://datacom.ashrae.org>

- Actionable feedback collected in Phoenix (thank you) has been incorporated into the latest version
- Some feedback (e.g., search, disable page likes) are limitations of ASHRAE's SharePoint
- Version 2 of the Datacom Encyclopedia published on 10/13/2025, fully incorporating the *Thermal Guidelines*, *Liquid Cooling*, *Design Considerations*, and *IT Equipment Design* Datacom books
- Updates published on Wetted Materials, Liquid Filtration, and Fluid Quality Considerations
- Continued feedback requested. Please email datacom@ashrae.net

Datacom Encyclopedia Navigation

Top Navigation

Click on the TOPIC that best meets your need:

 Facility Design Considerations	 Environmental Guidelines	 Cooling Technologies
 Energy Efficiency	 ITE Design Considerations	 Everything Else

The ASHRAE TC 9.9 Datacom Encyclopedia incorporates the former Thermal Guidelines for Datacom Equipment Centers, Design Considerations for Datacom Equipment Centers, Liquid Cooling Guidelines for Datacom Equipment Centers, and IT Equipment Design Impact on Data Center Solutions, in addition to new and updated material, in a convenient, searchable "wiki" style format.

The PDF version of the Datacom book series and the digital versions of Thermal Guidelines for Datacom Equipment Centers, Design Considerations for Datacom Equipment Centers, and Liquid Cooling Guidelines for Datacom Equipment Centers remain available via the top navigation bar.



Topic Navigation

TC 9.9 Technical Alerts

What's New

^ What's New

<p>January 22, 2025</p>	<ul style="list-style-type: none"> • Updated information on <ul style="list-style-type: none"> ◦ Wetted Materials (Version 2.1) including revised tables of common metal and metal alloys and elastomers, plastics, and other materials ◦ Liquid Filtration (Version 2.1) including revised guidance for TCS filtration to 25 micron and 5000 beta ratio ◦ Fluid Quality Considerations (Version 2.1) including expanded coverage of propylene glycol fluids
<p>October 13, 2025</p>	<ul style="list-style-type: none"> • Datacom Encyclopedia V2 launched. The ASHRAE TC 9.9 Datacom Encyclopedia incorporates the former Thermal Guidelines for Datacom Equipment Centers, Design Considerations for Datacom Equipment Centers, Liquid Cooling Guidelines for Datacom Equipment Centers, and IT Equipment Design Impact on Data Center Solutions
<p>June 24, 2025</p>	<ul style="list-style-type: none"> • Datacom Encyclopedia V2 (beta) launched
<p>May 10, 2025</p>	<ul style="list-style-type: none"> • Liquid-cooling Infrastructure Considerations for Technology Cooling Systems updated to introduce S20 and S25 classes • Clarification provided around S- vs. W-classes and CDU approach temperature
<p>March 5, 2025</p>	<ul style="list-style-type: none"> • The CDUs Critical Role of TCS and FWS Isolation in Cold Plate Deployments published. • PDF version also available in the ASHRAE Datacom Series PDFs page.

Note: A complete listing of all historical changes is available [here](#).

- Five most recent updates

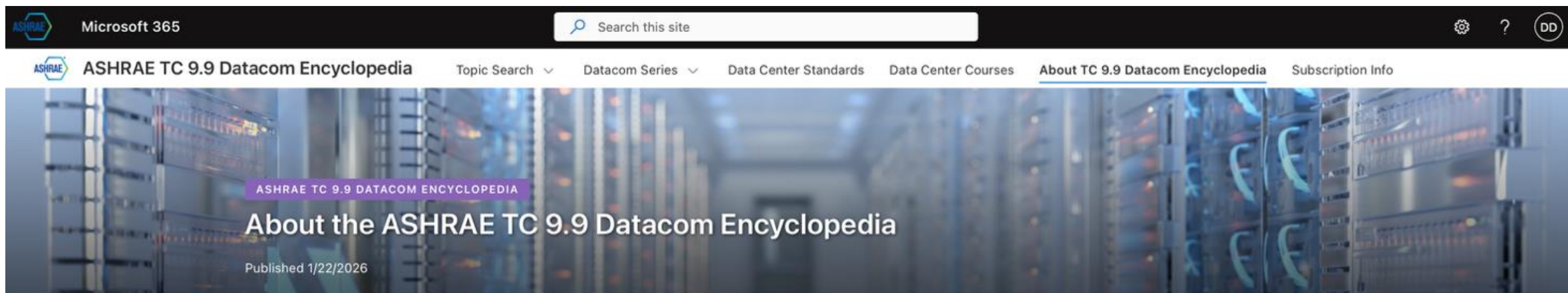

∨ **About the ASHRAE TC 9.9 Datacom Encyclopedia**

∨ **Complete Version History**

∨ **Encyclopedia Index**

∨ **Contact Information**

∨ **About TC 9.9**

∨ **Cite This Source**

^ Encyclopedia Index

Encyclopedia

[See all](#)

 Edit in grid view  Share  Copy link

 All Items 

Topic ↑	Content	Article
Content: Acoustics (1)		
Environmental Guidelines	Acoustics	Acoustics
Content: Air-cooling (3)		
Cooling Technologies	Air-cooling	Air-cooling
Cooling Technologies	Air-cooling	Air distribution
Cooling Technologies	Air-cooling	Air-cooling Transient Response
Content: Ancillary Spaces (1)		
Facility Design Considerations	Ancillary Spaces	Ancillary Spaces
Content: Availability and Reliability (1)		
Facility Design Considerations	Availability and Reliability	Availability and Reliability
Content: Commissioning (1)		
Everything Else	Commissioning	Commissioning

- Complete listing of all Topic pages

^ Complete Version History

January 22, 2025	<ul style="list-style-type: none"> Updated information on <ul style="list-style-type: none"> Wetted Materials (Version 2.1) including revised tables of common metal and metal alloys and elastomers, plastics, and other materials Liquid Filtration (Version 2.1) including revised guidance for TCS filtration to 25 micron and 5000 beta ratio Fluid Quality Considerations (Version 2.1) including expanded coverage of propylene glycol fluids
October 13, 2025	<ul style="list-style-type: none"> Datacom Encyclopedia V2 launched. The ASHRAE TC 9.9 Datacom Encyclopedia incorporates the former Thermal Guidelines for Datacom Equipment Centers, Design Considerations for Datacom Equipment Centers, Liquid Cooling Guidelines for Datacom Equipment Centers, and IT Equipment Design Impact on Data Center Solutions
June 24, 2025	<ul style="list-style-type: none"> Datacom Encyclopedia V2 (beta) launched
May 10, 2025	<ul style="list-style-type: none"> Liquid-cooling Infrastructure Considerations for Technology Cooling Systems updated to introduce S20 and S25 classes Clarification provided around S- vs. W-classes and CDU approach temperature
March 5, 2025	<ul style="list-style-type: none"> The CDUs Critical Role of TCS and FWS Isolation in Cold Plate Deployments published. PDF version also available in the ASHRAE Datacom Series PDFs page.
November 7, 2024	<ul style="list-style-type: none"> Liquid Cooling thermal template published in Thermal Guidelines for Data Processing Environments, Chapter 6 (Version 1.1)
September 2, 2024	<ul style="list-style-type: none"> Liquid Cooling: Resiliency Guidance for Cold Plate Deployments published. PDF version also available in the ASHRAE Datacom Series PDFs page.

- Complete listing of all Historical Versions

ASHRAE TC 9.9 DATACOM ENCYCLOPEDIA

ASHRAE Datacom Series PDFs

Published 6/27/2025

The ASHRAE Datacom Series is a series of books (in print and PDF formats) that provides comprehensive treatment of data center cooling and related subjects, authored by ASHRAE Technical Committee 9.9, Mission Critical Facilities, Data Centers, Technology Spaces and Electronic Equipment. The first book, Thermal Guidelines for Data Processing Environments, was published in 2004. Since then, the series has grown to 14 books, several with multiple editions.

Over time, the pertinent information from these books will be incorporated into this ASHRAE TC 9.9 Datacom Encyclopedia, with the encyclopedia content superseding the content in the published books. For the purpose of historical reference, every edition of all 14 books of the ASHRAE Datacom Series will remain available here in PDF format. These PDFs are for viewing purposes only - users may not download or print these books.

Datacom Books

 Name	Publication Year
 01-1_ThermalGuidelines_1st Ed_90431.pdf	 2004
 01-2_ThermalGuidelines_2nd Ed_90443.pdf	 2009
 01-3_ThermalGuidelines_3rd Ed_90453.pdf	 2012
 01-4_ThermalGuidelines_4th Ed_90577.pdf	 2015

- Added publication date column

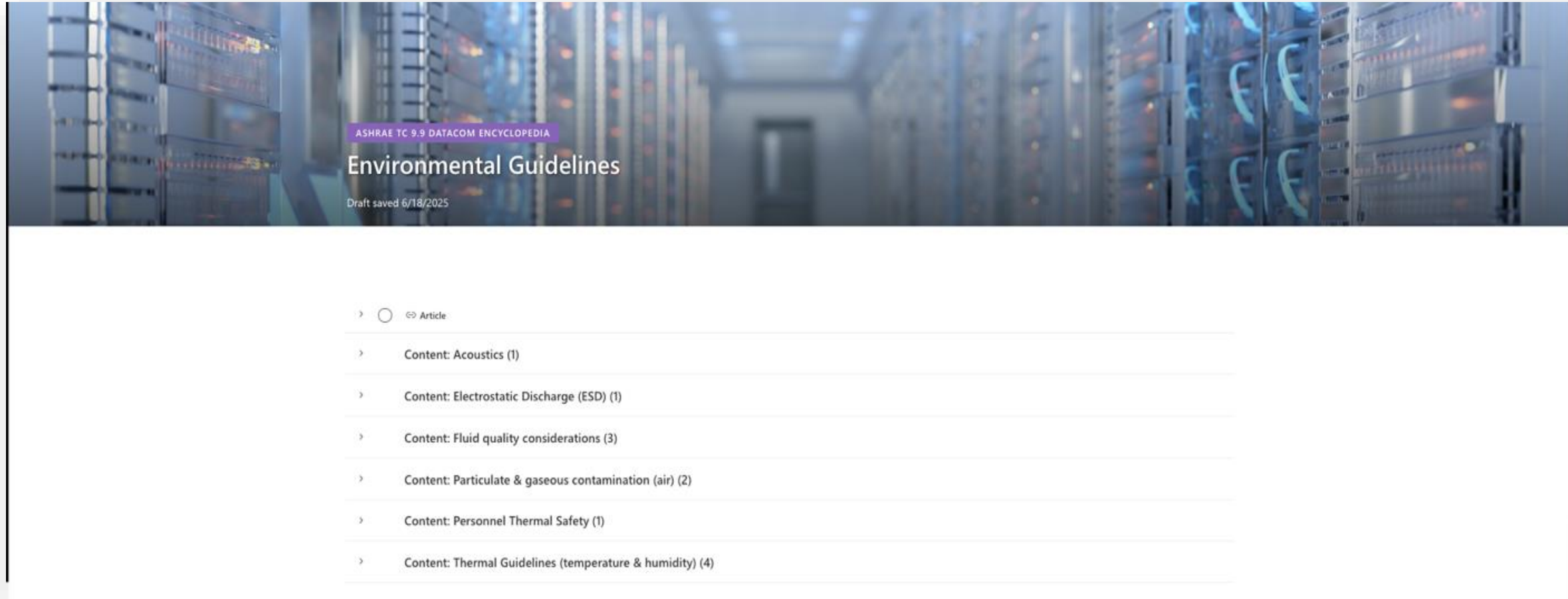

- Single click to get to a sub-navigation of all articles related to *Environmental Guidelines*

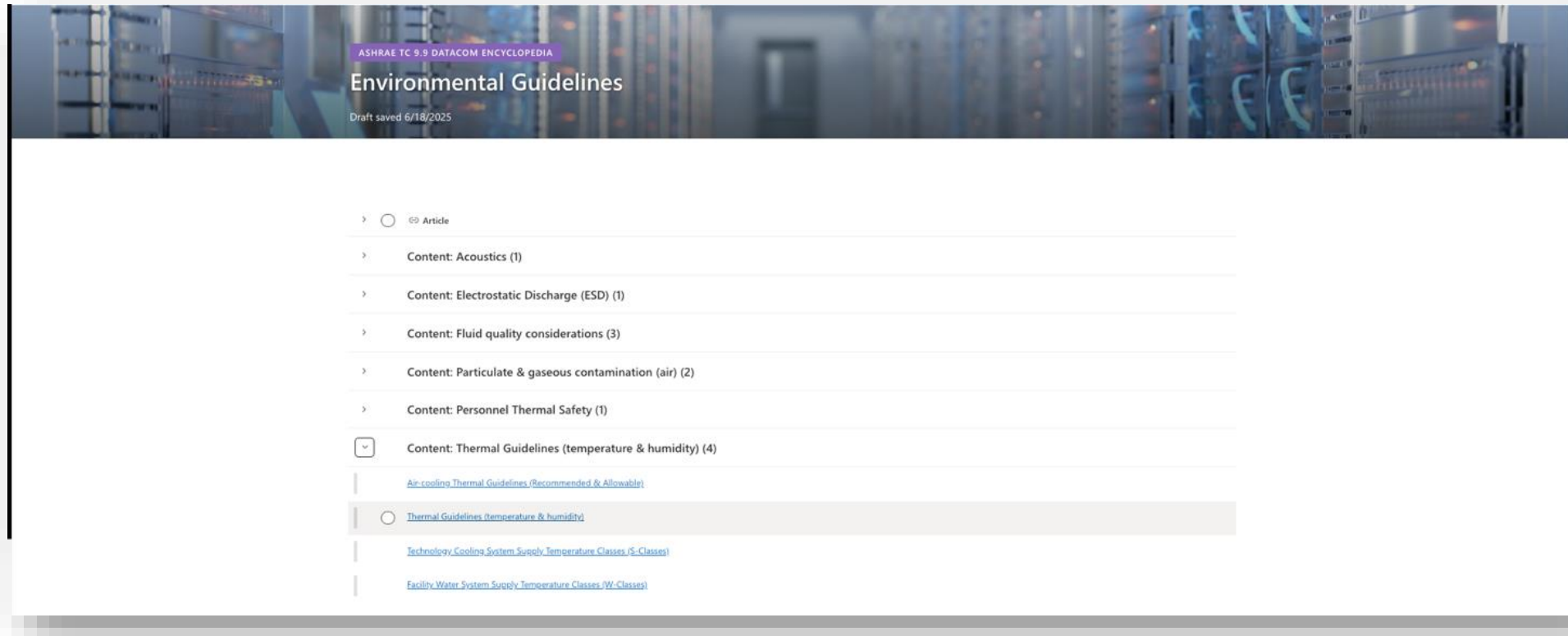

- Expandable table to see primary articles related to *Environmental Guidelines > Thermal Guidelines (temperature & humidity)*
- Not all articles will be listed in the navigation
- Navigation is meant to get you “close”
- Encyclopedia search can be used if a very specific topic is requested

ENVIRONMENTAL GUIDELINES

Air-Cooling Thermal Guidelines (recommended & allowable)

Draft saved 2/3/2025

Direct link to older books

In the [fifth edition of Thermal Guidelines](#) (2021), more enhancements to the recommended envelope were made to aid in data center energy improvements.

Environmental Guidelines for Air-Cooled Equipment Definitions

These data center environmental guidelines were developed by members of the ASHRAE TC 9.9 committee representing information technology equipment (ITE) manufacturers.

These environmental guidelines are for terrestrial-based systems and do not cover electronic systems designed for aircraft or spacecraft applications. The term server is used to generically describe any ITE, such as servers, storage, and network products, used in data-center-like applications.

Several key definitions need to be highlighted:

recommended environmental range:

- Facilities should be designed to achieve, under normal circumstances, ambient conditions that fall within the recommended range.
- This recommended range may be as defined either as [stated below](#) or by the [process outlined](#) whereby the user can apply metrics to define a different recommended range more appropriate to meet specific business objectives.
- The recommended envelope was chosen based on a number of inputs, the primary being reliability of ITE, power increases of ITE with higher ambient temperatures, acoustical impacts with higher ambient temperatures, and providing a buffer for excursions to the allowable limits caused by facility cooling fails.

allowable environmental envelope:

- The allowable envelope is where IT manufacturers test their equipment to verify.
- To enable the greatest latitude in use of all the classes, power and thermal management excursions outside the capability of the ITE under extreme load conditions.
- Typically, IT manufacturers perform a number of tests prior to the announcement of the allowable environmental envelope.
- This is not a statement of reliability but one of the functionality of the ITE. In an allowable envelope, dew point (DP) and maximum elevation values are part of the allowable operating conditions.

Direct link to figures, images, etc

Page Topics

- Environmental Guidelines for Air-Cooled Equipment...
- Overview of the Latest Edition of the Air-Cooled...
- 5th Edition of the Air-Cooled Equipment...
- Environmental Class Definitions for Air-Cooled...
- Environmental Class Definition for High-Density Air-Cooled...
- Altitude Derating
- Allowable Server Inlet RH Limits versus Maximum...
- Allowable Server Inlet Temperature Rate of Change

Supplemental Information

Related Topics

- Thermal Guidelines
- Technology Cooling System Supply Temperature Classes (S-Classes)
- Relationship Between TCS and FWS Classes

References

Versions

Links to other topics

References

- Zhang, J., R. Zhang, R. Schmidt, J. Gilbert, and B. Guo. 2019. Impact of gaseous contamination and high humidity on the reliable operation of information technology equipment in data centers. ASHRAE Research Project 1755, Final Report. Peachtree Corners, GA: ASHRAE.
- Pommerenke, D., A. Talezadeh, X. Gao, F. Wan, A. Patnaik, M. Moradian-pouchehraz, and Y. Han. 2014. The effect of humidity on static electricity induced reliability issues of ICT equipment in data centers. ASHRAE RP-1499 Final Report. Peachtree Corners, GA: ASHRAE.
- ISO. 2015. ISO 14644-1:2015, Cleanrooms and associated controlled environments—Part 1: Classification of air cleanliness by particle concentration. Geneva: International Organization for Standardization
- ETSI. 2014. ETSI EN 300 019-1-3 V2.3.2, Equipment engineering (EE); Environmental conditions and environmental tests for telecommunications equipment; Part 1-3: Classification of environmental conditions; Stationary use at weather protected locations. Valbonne, France: European Telecommunications Standards Institute.

^ Versions	
2.1	<p>This revision contains editorial changes and the following technical changes:</p> <ul style="list-style-type: none"> • New tables for common metal and metal alloys and elastomers, plastics, and other materials. • Guidance on test methods for material compatibility • Guidance on the use of silver in braze materials
2.0	Wetted Materials topic created

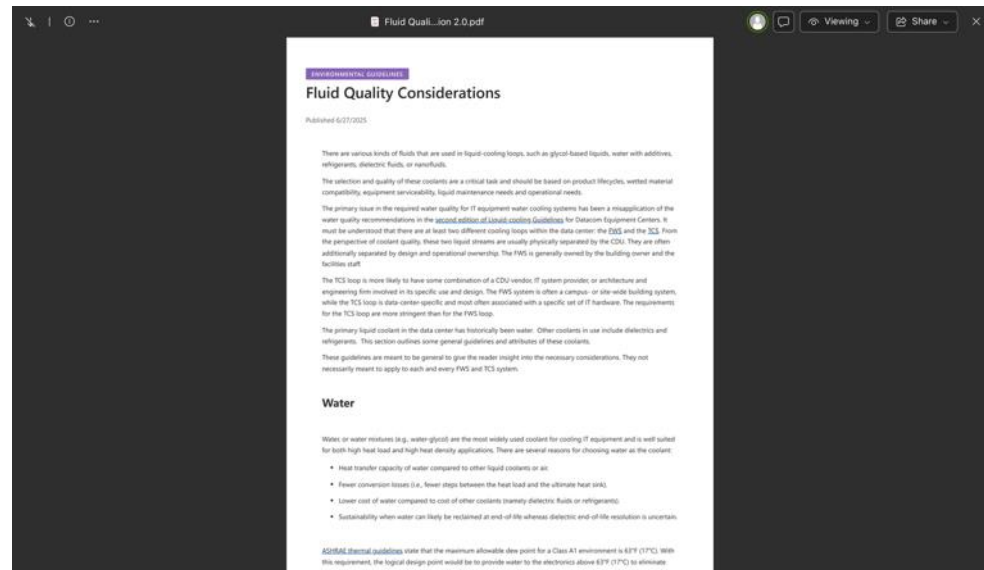
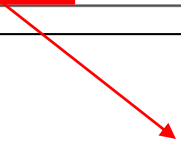

- Individual topics can be searched
- Unfortunately, limitations of SharePoint means search within the topic is possible

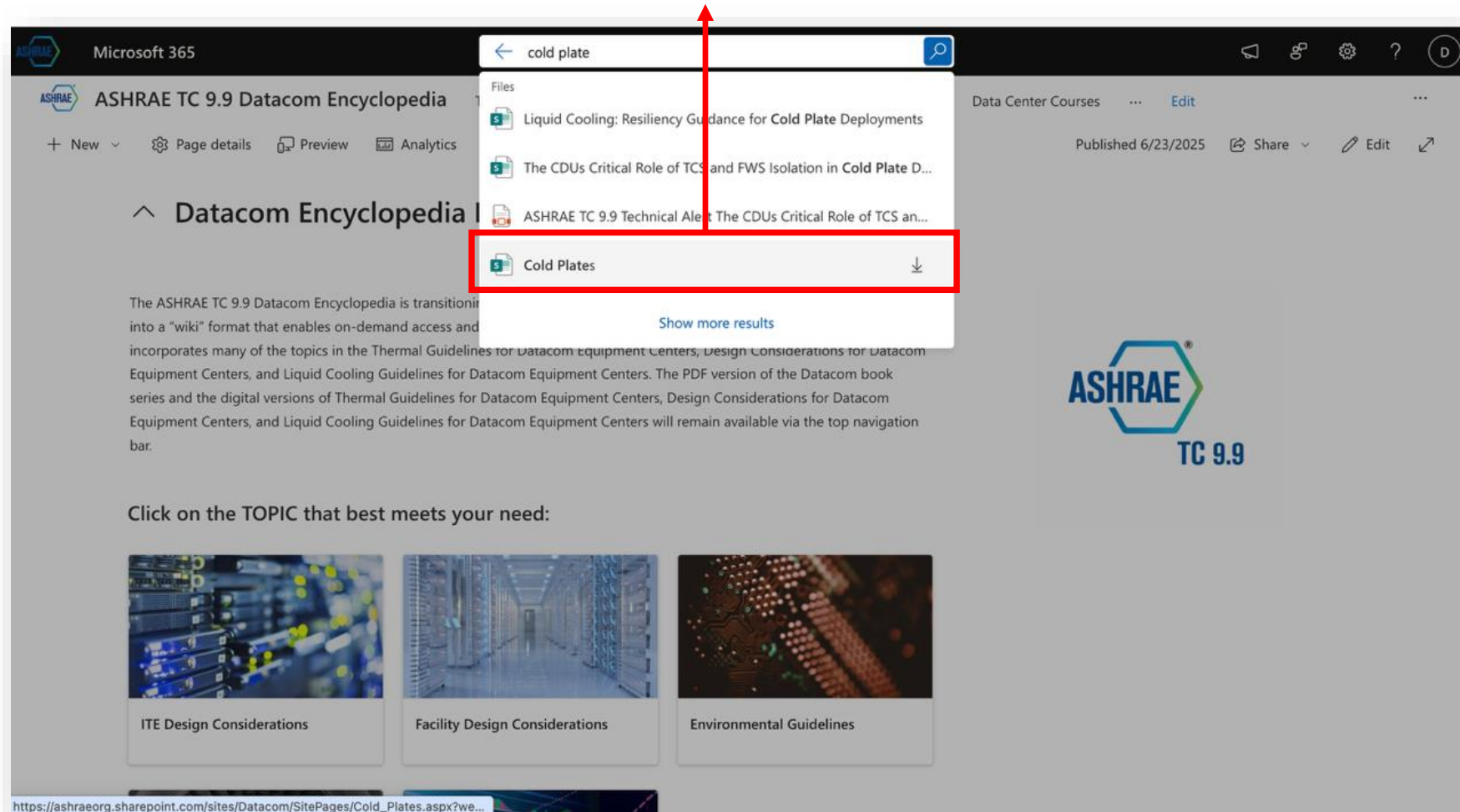

IT Manufacturers Subcommittee

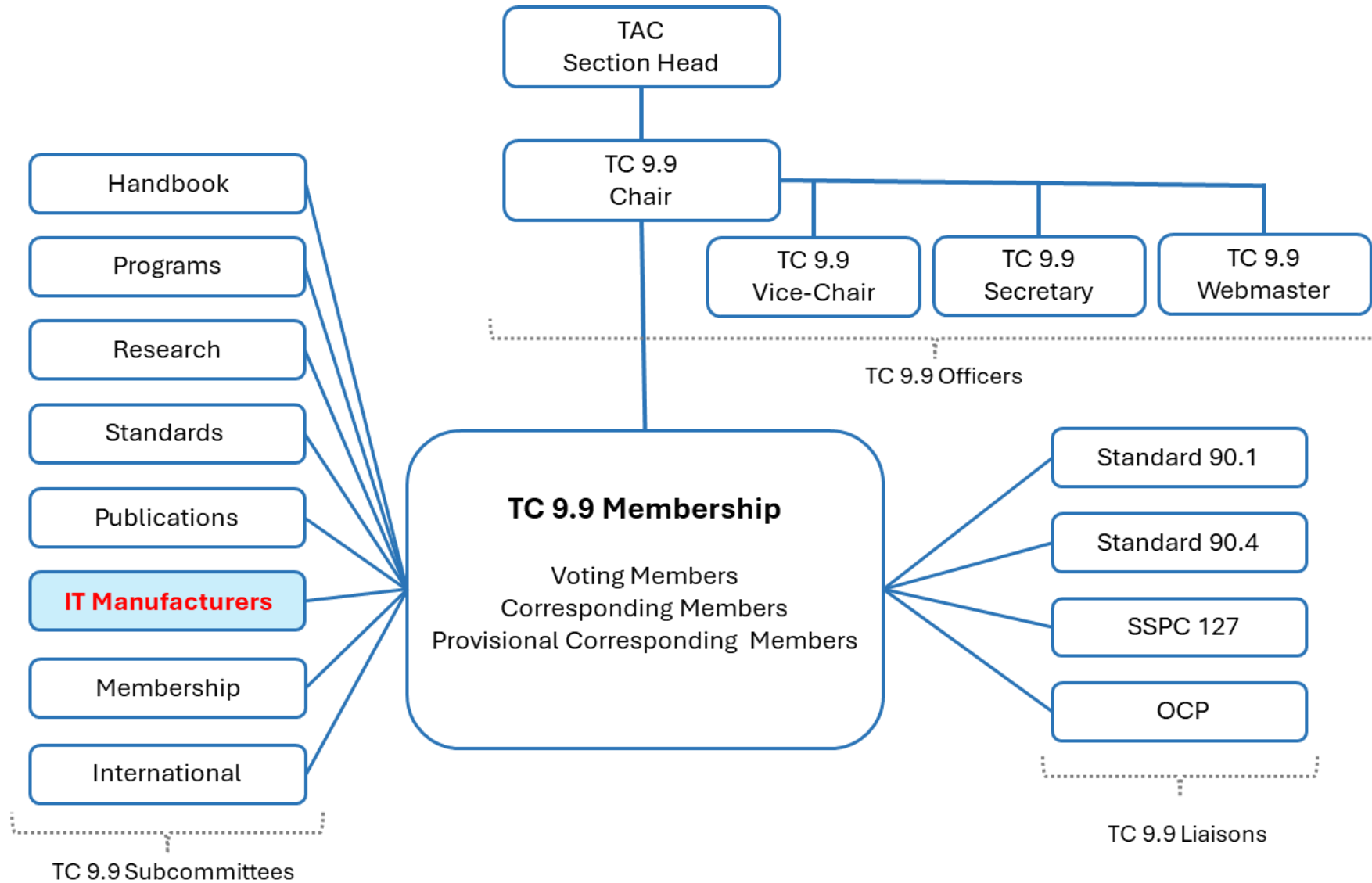

AGENDA

Topic	Duration (minutes)
Subcommittee Structure	5
Datacom Encyclopedia Update	10
CDU Safety Testing (IEC 62368-1)	5
Tech Brief Roadmap	10

- IT Subcommittee Meeting Format
 - Winter and Summer meetings will be primarily “in-person” working meetings.
 - Brief (< 1 hour) status, 1 – 2 hour work session of predefined topics
 - Work session will be focused on content development
 - Spring (~April) and Fall (~October) meetings will be status
- Monthly Meeting
 - Work session with a pre-announced topic
 - Third Friday of the Month at 11:00 am Eastern
 - Kick off on Friday February 20, 2026
 - Join if the topic is of interest
- Email Dustin dwdemetr@us.ibm.com if you’re not on the distribution list

- Discussion at the summer conference
 - Wetted Materials lists are diverging between ASHRAE and OCP
 - ASHRAE's general wetted materials are for BTA / water
 - Need to update for PG25 and align to OCP documents that have wetted material list and general PG25 guidance
- Updates made to the datacom encyclopedia:
 - New wetted materials lists, e.g.,
 - Refinement of copper alloys
 - Elimination of tape pipe sealants
 - Updated plastics and elastomers (PVDF, FKM, etc.)
 - Fluid quality, e.g.,
 - Updated turbidity for water
 - Expanded coverage of propylene glycol fluids (aligned to OCP), including new tables on Fluid quality guidelines for propylene glycol TCS loops and Water quality guidelines for diluting propylene glycol, information of thermal stability, and antifoam.

Common metal and metal alloys found in FWS and TCS loops			
Material	FWS	TCS	Notes
Aluminum and aluminum alloys			<ul style="list-style-type: none"> Aluminum should be avoided in TCS loops because of its potential as a galvanic catalyst of other metals. Aluminum could be considered provided there is proper surface treatment of the metal (via coatings or other proprietary methods) such that the aluminum is not directly exposed to the same liquid as other metals.
Brass with < 15% zinc	X	X	<ul style="list-style-type: none"> Chrome and/or nickel plating can be applied to brass to improve its durability, corrosion resistance, and appearance. If used, care should be taken to ensure the plating is not worn away, particularly in uses such as quick disconnect couplings. The use of brass with < 15% zinc minimizes the risk from dezincification.
Carbon steel	X		<ul style="list-style-type: none"> For use with FWS solutions that use a CDU only. Carbon steel may be used in FWS provided that steel-specific corrosion inhibitor(s) are added to the system and proper inhibitor concentration is maintained.
Copper	X	X	<ul style="list-style-type: none"> There are many types of copper alloys used in FWS. For TCS systems, CDA 110, CDA122, CDA 145, CDA 220, and CDA 220 should be used. Copper should be < 15% zinc and lead free.
Stainless Steel, solution treated and passivated	X	X	<ul style="list-style-type: none">

Common elastomers, plastics, and other materials found in FWS and TCS loops			
Material	FWS	TCS	Notes
Acrylonitrile butadiene rubber (NBR)	X		<ul style="list-style-type: none"> Also known as Nitrile Rubber and Buna-N
Chlorinated Polyvinyl Chloride (CPVC)	X		
Ethylene Propylene Diene Monomer (EPDM)	X	X	
Fluoroelastomer (FKM)	X	X	<ul style="list-style-type: none"> A specific brand is Viton™ A-Type, Viton™ GF, Viton™ ETP
Fluorinated ethylene polypropylene (FEP)		X	
Polyetheretherketone (PEEK)		X	
Polyphenylene sulfide (PPS)		X	
Polysulfone or polyphenylsulfone (PSU, PPSU)	X	X	
Polypropylene (PP)	X	X	
Polytetrafluoroethylene (PTFE)	X	X	<ul style="list-style-type: none"> A specific brand is Teflon™. As noted below, the improper use of PTFE tape sealant has caused issues in TCS systems when it has been improperly applied and released into the fluid stream and should be avoided.

Fluid quality guidelines for propylene glycol TCS loops [↔](#)

Parameter	Propylene Glycol (25% vol.)	Notes
pH at 20°C (68°F)	8.0 to 10.5	
Corrosion inhibitor(s)	Required	In m
Freeze point	-13°C to -10°C (9°F - 14°F)	
Biocide	Not recommended	
Reserve alkalinity	>6 mL	TI fo cc ap H tr
Sulfide	<< 1 ppm	Ar in de
Sulfate	<10 ppm	
Chloride	<5 ppm	
Bacteria	<100 CFUs/mL	
Total hardness (as CaCO ₃)	<25 ppm	
		TI fo

Water quality guidelines for diluting propylene glycol

Parameter	Value
Appearance	Colorless & odorless
pH at 20°C (68°F)	5.0 - 9.0
Chloride ion content, ppm	< 25
Conductivity at 20°C (68°F)	25 mS/cm
Sulphate content, ppm	
Total hardness (CaCO ₃ + MgCO ₃), ppm	
Total suspended solids, ppm	
Calcium, ppm	
Magnesium, ppm	
Iron, ppm	
Filtration	
Bacteria	

Water quality guidelines for the FWS and TCS loops

Parameter	FWS	TCS
pH	7 to 9	8.0 to 9.5
Corrosion inhibitor(s)	Required	Required
Biocide	Required	Required
Sulfide	<10 ppm	<1 ppm
Sulfate	<100 ppm	<10 ppm
Chloride	<50 ppm	<5 ppm
Bacteria	<1000 CFUs/mL	<100 CFUs/mL
Total hardness (as CaCO ₃)	<200 ppm	<20 ppm
Conductivity	—	0.2 to 20 micro-ohm/cm (See Note 1)
Total suspended solids	—	<3 ppm
Residue after evaporation	<500 ppm	<50 ppm
Turbidity	<20 NTU (Nephelometric)	<5 NTU (Nephelometric)

Note 1: The value for the conductivity is most important for the quality of make-up water being added to a TCS loop. In addition, conductivity should be charted over time and the root cause of any changes or deviations should be understood.

- Discussion at the summer conference
 - Update ASHRAE filtration recommendation:
 - 25-micron
 - Add beta ratio
 - Side stream provision without filter size recommendation
- Updates made to the datacom encyclopedia:
 - Expanded description of filter capability, including beta ratio and efficiency
 - Expanded information on filter performance measures
 - Revised guidance for TCS filtration to 25 micron and 5,000 beta ratio
 - Design and operational considerations for finer filtration

- Concerns regarding the Tubing and Fitting Compatibility Test required in IEC/UL 62368-1 in regard to complex liquid cooling systems were brought to the IT Subcommittee
 - 3rd edition Sec. G.15.2.3
 - 4th edition G.15.2.3 for self-contained equipment and G.15.3.4 for modular equipment
- IT Subcommittee approached TC108 USTAG to seek formal guidance to determine if certification of stand-alone CDUs to IEC 60335-2-40 is acceptable and the CDU is not classified as ITE equipment and is not within the scope of IEC/UL 62368-1 unless the communication interface is used for functional control by information-processing equipment.
- Interpretation submitted to IEC Chairman's Advisory Group for review.
- Expected resolution in 1Q 2026

- 62368 requires testing every potential combination of non-metallic material and cooling fluid
 - This results in thousands of test samples for a complex, commercially available system (ref example below)
 - This in turn directly impedes the system manufacturer's speed to market and increases development costs
 - The high number of samples required and long test duration can also potentially overwhelm the various NRTL's
- 62368 requires a very specific “dog-bone” form factor for tensile testing pre/post conditioning
 - System manufacturer is not necessarily procuring the non-metallic sub-component directly.
 - Drilling down to 3rd or 4th tier vendors to get the material samples made in custom form factors can be very challenging
 - For example, say vendor A buys a ball valve from vendor B to use in their unit. Vendor B uses an O-ring in their valve which they get from vendor C. Vendor A now has to navigate through multiple communication layers and convince vendor C to provide the custom samples
 - Testing specific coolant blends and vendor specific polymers/rubbers implies these are now controlled components
 - This would limit the customer base from taking full advantage of the plethora of fluid vendors out there and potentially limit them to a select few.
 - Manufacturers would be hampered in their ability to second source components, as introducing an alternate would trigger another round of sample gathering and compatibility testing
 - Many hydraulic components are COTS parts sold in very high volume, the makers of these parts are very unlikely to notify their customers if they switch from one gasket vendor to another for example. The cooling system manufacturer won't have visibility to if their vendor's, vendor's, vendor makes a change



- 2029 National Electrical Code



- The 2029 National Electrical Code (NFPA 70) is undergoing a major structural reorganization to improve coordination with the International Building Code (IBC) Chapter 27 (Electrical)
- Intent is to improve code correlation, global applicability, and modern infrastructure
 - Occupancy-based alignment With ICC Codes
 - NEC content for specific occupancies (e.g., healthcare, data centers, EV infrastructure, emergency systems) is being grouped more logically
 - Mirrors how IBC Chapters 27 and 4–10 organize building systems by occupancy and hazard type
 - Clearer voltage and energy classifications (NEC versus IEC)
 - Make it easier to identify where IEC-rated equipment can meet NEC intent



- Moving from the long-standing 9-chapter layout to a 20+ chapters
- NFPA 70-2026 Articles 645 (Information Technology Equipment) and 646 (Modular Data Centers) are moving to Chapter 23

Chapter 23 – Data Centers and Information Technology Equipment

Article 2300 – General Requirements

Scope

Listing

Reconditioning

Grounding/Bonding

Wiring Methods (including flexible cord usage)

Article 2302 – Information Technology Equipment Rooms (645 requirements not covered in Article 2300)

Article 2304 – Data Center Facility

Article 2306 – IT Specific Equipment

PDU's (including "Side Cars")

IT PDU's (power limited)

Solid State Transformer (?)

Article 2308 – Liquid Cooled Systems

Article 2310 – Superconductors

Article 2312 – Fault Managed Power for Data Centers

Article 2314 – Cybersecurity



- Need a few SSPC 90.4 and/or TC 9.9 experts to assist with the requirements
- Only applies only to electrical safety aspects of liquid cooled systems, including, but not limited to
 - Power distribution equipment
 - Associated controls, sensors, and actuators
 - Fault detection and protective interfaces
 - Electrical separation from liquids

Article 100 Definitions

Liquid-Cooled System. A system that uses a liquid heat-transfer medium to remove heat from ~~electrical or electronic information technology~~ equipment by means of direct contact or indirect heat exchange, including associated piping, pumps, valves, heat exchangers, containment, controls, and monitoring, where the liquid is circulated to transport heat away from energized components.

Immersion Cooling System.

A ~~liquid-cooling-cooled~~ system in which information technology equipment, or portions thereof, are operated while submerged in a dielectric liquid that provides thermal management by direct contact with energized components.

Article 2308 Liquid Cooled Systems

Part I. General

2304.1 Scope. This article covers the use, installation, and construction specifications for liquid-cooled systems.

2308.2 Listing Requirements. Liquid-cooled systems shall be listed.

~~2308.3 Reconditioned Equipment. The installation of reconditioned liquid-cooled system equipment shall not be permitted.~~

Part II. Installation

Part III. Disconnecting Means

Part IV.

Commented [ER1]:
Replaced “electrical or electronic” with “information technology” to align with scope.

Commented [ER2]:
Added “liquid-cooled system” to align with scope.

Commented [ER3]:
Scope to consider...
Definition(s)
Scope
Listing
General Requirements
Wiring Methods
Grounding & Bonding
Overcurrent Protection
Disconnecting Means
Leakage Detection and Interlocks
Immersion Cooling-Specific Requirements
Pumps, Motors, and Control Equipment
Marking and Documentation
Working Space

Commented [ER4R3]: Do we need to address “in-rack cooling systems?”

Commented [ER5]:
Do listing requirements cover all applications?

Commented [ER6]:
Added reconditioned equipment



BACKUP



- The Department of Energy (DOE) mandates minimum efficiency levels for distribution transformers depending on
 - Transformer type (Low-voltage dry-type vs. Liquid-immersed)
 - Manufacture date
 - kVA rating
 - Phase (Single-phase or Three-phase)
- All efficiencies are measured at 35% of nameplate rated load per the DOE test procedure in Appendix A to Subpart K



- Adopts amended (more stringent) minimum energy-efficiency standards for distribution transformers under 10 CFR §431
- Compliance with these new standards is required beginning April 23, 2029

Type	Rating (kVA)	Pre2029 (%)	Post2029 (%)
LVDT	15	97.7	98.39
LVDT	25	98	98.6
LVDT	37.5	98.2	98.74
LVDT	50	98.3	98.81
LVDT	75	98.6	98.88
LVDT	112.5	98.74	98.99
LVDT	150	98.83	99.06
LVDT	167	98.7	99.09
LVDT	225	98.94	99.15
LVDT	250	98.8	99.16
LVDT	300	99.02	99.22
LVDT	333	98.9	99.23
LVDT	500	99.14	99.31
LVDT	750		99.38
LVDT	1000		99.42

LVDT = Low-voltage dry-type distribution transformers

Type	Rating (kVA)	Pre2029	Post2029
MVDT	15kVA 20-45kV	98.1	98.29
MVDT	15kVA 46-95kV	97.86	98.07
MVDT	15kVA >=96kV	98.53	
MVDT	30kVA 20-45kV	98.33	98.11
MVDT	30kVA 46-95kV	98.12	97.87
MVDT	30kVA >=96kV	98.63	NA
Liquid	10	98.62	NA
Liquid	15	98.76	NA
Liquid	25	98.91	NA
Liquid	37.5	99.01	NA
Liquid	50	99.08	NA
Liquid	75	99.17	NA
Liquid	100	99.23	NA

MVDT = Medium-voltage dry-type distribution transformers

Liquid-immersed distribution transformers - Post-2029 requirements are only described qualitatively (e.g., 10–20% loss reduction), but no numeric efficiency table has been published

Goal: Speed to market

- a. **Technical Alert / Advisory** - Time sensitive
- b. **Technical Snapshot** - Single technical topic - limited scope to achieve speed to market
- c. **Technical Bulletin** - Single technical topic - full detail created using a strong outline

Approach

- Small team(s), put together document, following template
- 1-week review and comment by IT Subcommittee
- 1-week review and vote by TC 9.9
- Publish in datacom encyclopedia, with extract published publicly for first release
- Updates made to datacom encyclopedia version only
- Technical Briefs mapped to datacom topics

- Tech Brief has been valuable and well received but we need to accelerate their publication to have a real impact
- **Goal is to publish 2 tech briefs every 6 months**
- IT Subcommittee monthly meetings will focus on 1x Tech Brief a month to draft content based on a pre-defined outline for prioritized topics
 - Ranking to determine top needs for the next 6 months
 - Lead needs to be identified for the topic
- Outlines can be worked on offline when people have time

- Enabling asynchronous collaboration (Google Drive)
 - Request access by emailing tc99publications@gmail.com
 - Must have a gmail address
 - Looking to find another platform to make this easier

Tech Brief Roadmap			
Tr Subject	Status	Related files	Tr Lead
ITE Power Trends	In pr...	ITE Power Tre...	Dustin Demetriou
Fluid Testing and Maintenance	Not s...	Fluid Testing a...	
Liquid Cooling TCO	Not s...	Liquid Cooling ...	
Fluid Quality	Not s...	Fluid Quality	
Multi-Loop FWS Design	Not s...	File	
S20/S25 Justification	Not s...	File	
Liquid Cooling Deployment Questions	In pr...	Liquid Cooling ...	John Gross
Bleeding Fluid Networks	Not s...	File	
L2A CDU Trends	Not s...	File	
	Not s...	File	

Main TC 9.9 Meeting Closed

ASHRAE TC 9.9 Website



<https://tc0909.ashraetcs.org>

2026 Winter Attendance Form

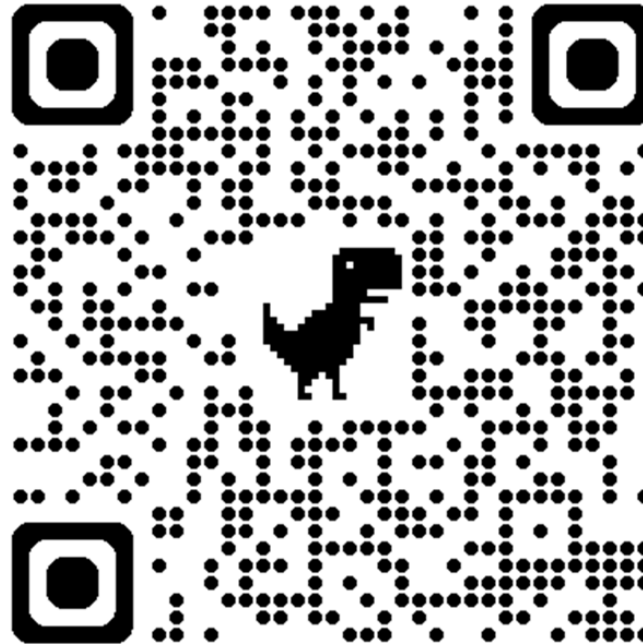

<https://forms.gle/3oAAsj5ZVHqT9f6M6>

Datacom Encyclopedia

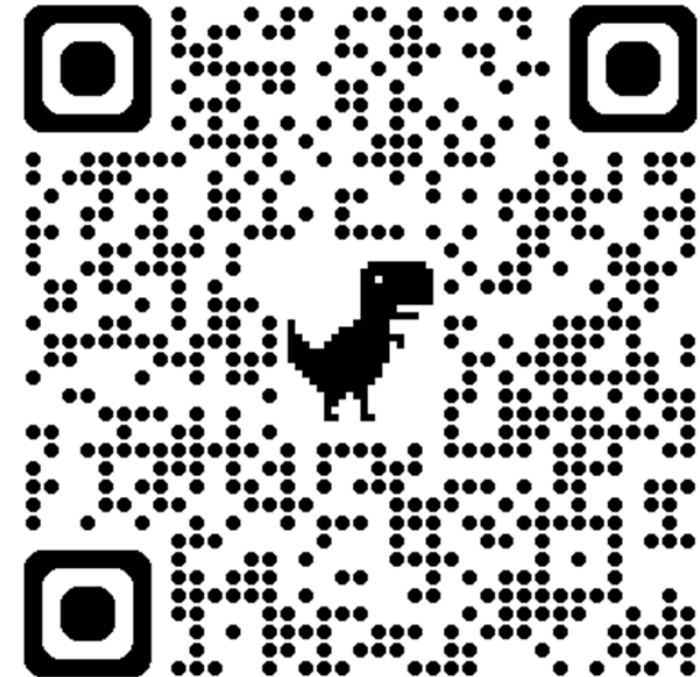

<https://datacom.ashrae.org>